

**DATE:** March 4, 2024

**MEMO TO:** Paras Parekh, Chair  
Planning Committee

**FROM:** Ken Jones  
Director of Land Preservation

**RECOMMENDATION:** Recommend approval of a Resolution approving a Recreational Lease with Commonwealth Edison (ComEd) at Kestrel Ridge, Rollins Savanna, and Lake Carina Forest Preserves.

**STRATEGIC DIRECTIONS SUPPORTED:** Public Access and Connections; Organizational Sustainability.

**FINANCIAL DATA:** The lease calls for a nominal rent of \$1.00.

**BACKGROUND:** On May 11, 2010 the Board of Commissioners approved a recreational lease agreement with ComEd for a 10-year lease term allowing the District to operate and maintain a multi-use public trail on ComEd's right-of-way (ROW).

The original lease has expired. The lease that would be approved by the attached resolution would replace the original lease and provide the District the continued legal right to use ComEd's ROW for the operation and maintenance of the trail. The initial term of the lease is for ten years, with an option for the District to renew the lease for one additional ten-year term. This leased property includes: (i) a segment of trail at Kestrel Ridge west of Fairfield Road and on both sides of Nippersink Road; (ii) two segments of the Millennium Trail at Rollins Savanna north of the parking lot on the east side of Drury Lane, and west of Carillon Drive to District-owned property south of the intersection of Hook Drive and Rollins Road; and (iii) a segment of the loop trail at Lake Carina Forest Preserve east of the District's parking lot on Milwaukee Avenue and south of Interstate 94.

Upon approval by the District, the lease will be provided to ComEd for execution. ComEd requires the District to execute the lease first.

**REVIEW BY OTHERS:** Executive Director, Chief Operations Officer, Director of Finance, Manager of Board Operations and Corporate Counsel.

STATE OF ILLINOIS     )  
  ) SS  
COUNTY OF LAKE     )

**BOARD OF COMMISSIONERS  
LAKE COUNTY FOREST PRESERVE DISTRICT  
REGULAR MARCH MEETING  
MARCH 13, 2024**

**MISTER PRESIDENT AND MEMBERS OF THE BOARD OF COMMISSIONERS:**

Your **PLANNING COMMITTEE** presents herewith “A Resolution approving a Recreational Lease with Commonwealth Edison at Kestrel Ridge, Rollins Savanna, and Lake Carina Forest Preserves” and requests its approval.

**PLANNING COMMITTEE:**

Date: 3-4-2024     Roll Call Vote: Ayes: \_\_\_ Nays: \_\_\_  
                           Voice Vote Majority Ayes; Nays: 0

**LAKE COUNTY FOREST PRESERVE DISTRICT  
LAKE COUNTY, ILLINOIS**

**A RESOLUTION APPROVING A RECREATIONAL LEASE WITH  
COMMONWEALTH EDISON AT KESTREL RIDGE, ROLLINS SAVANNA, AND  
LAKE CARINA FOREST PRESERVES**

**WHEREAS**, the Planning Committee (the “Committee”) of the Lake County Forest Preserve District (the “District”) has determined that it is necessary and desirable to continue to lease certain property (the "Property") from Commonwealth Edison Company ("Owner") for public trails; and

**WHEREAS**, the Property will continue to be used as part of the District’s trail system, will continue to provide expanded forest preserve recreational opportunities in Lake County, and is a visual, topographic and ecologic extension of District properties; and

**WHEREAS**, the District has complied with all statutory procedures required for the lease of the Property; and

**WHEREAS**, Owner is willing to enter into a recreational lease with the District in the form attached hereto for the District’s lease of the Property (the “Recreational Lease”); and

**WHEREAS**, the Recreational Lease grants to the District the option of renewing the Recreational Lease for one additional 10-year term (the “Renewal Term”); and

**WHEREAS**, the Committee has recommended that the District approve the Recreational Lease because it will advance the goals and policies of the District; and

**WHEREAS**, it is in the best interests of the District to approve the Recreational Lease in substantially the form attached hereto;

**NOW, THEREFORE, BE IT RESOLVED** by the Board of Commissioners of the Lake County Forest Preserve District, Lake County, Illinois **THAT**:

**Section 1: Recitals.** The recitals set forth above are incorporated as a part of this Resolution by this reference.

**Section 2: Ownership and Boundaries.** The Property is privately owned, is depicted on Exhibit A on the Recreational Lease, and lies wholly within the limits of the District.

**Section 3: Suitability.** The Property is suitable to be used and maintained for forest preserve and related purposes, and it is necessary and desirable for the District to approve the Recreational Lease.

**Section 4: Approval of Recreational Lease.** The Recreational Lease is hereby approved. The District shall lease the Property from the Owner, upon the terms and conditions of the Recreational Lease. In addition, the President is hereby authorized to approve the Renewal Term on behalf of the District if he or she determines that, at the time of such approval, it continues to be in the

District's best interests to lease the Property from the Owner under the terms of the Recreational Lease. The President, Secretary and Executive Director of the District are hereby authorized and directed to execute and attest to, on behalf of the District, the Recreational Lease, all other documents that are necessary to complete such transaction, and all other documents necessary to extend the Recreational Lease for the Renewal Term if the Renewal Term is approved by the President at the appropriate time, provided that all such the documents have first been approved by the District's Corporate Counsel.

**Section 5: Severability.** If any provision of this Resolution is held to be invalid by a court of competent jurisdiction that provision shall be stricken from this Resolution, and the remaining provisions shall continue in full force and effect to the fullest extent possible.

**Section 6: Effective Date.** This Resolution shall be in full force and effect from and after its passage and approval in the manner provided by law.

PASSED this \_\_\_\_ day of \_\_\_\_\_, 2024

AYES:

NAYS:

APPROVED this \_\_\_\_ day of \_\_\_\_\_, 2024

---

Angelo D. Kyle, President  
Lake County Forest Preserve District

ATTEST:

---

Julie Gragnani, Secretary  
Lake County Forest Preserve District

Exhibit No. \_\_\_\_\_

RECREATIONAL LEASE  
February 1, 2024  
by and between  
COMMONWEALTH EDISON COMPANY  
and  
LAKE COUNTY FOREST PRESERVE DISTRICT

For and including the following described real estate

**CONTRACT NUMBER: 20100037**

**R/W Name: WAUKEGAN – CRYSTAL LAKE R/W**

**PARCELS: T41-36, T42-37, T42-38, T42-39, T42-48, T42-49, T42-50, T42-51, T42-51A, T42-52, T42-53 IN AVON TOWNSHIP**

**SW ¼ SECTION 19, TOWNSHIP 45, RANGE 10E**

**OF THE THIRD PRINCIPAL MERIDIAN**

**LAKE COUNTY – AVON TWP, ILLINOIS**

**COMED REGION NORTH**

**PIN: 06-30-300-014, 06-30-100-005, 6-30-100-001, 06-15-300-029, 06-15-400-001, 06-15-400-002, 06-14-300-001, 06-14-400-001, 07-27-200-001**

**RECREATIONAL LEASE**

THIS RECREATIONAL LEASE (the “**Lease**”) is made as of February 1, 2024 by and between COMMONWEALTH EDISON COMPANY, an Illinois corporation (“**Landlord**”) and the LAKE COUNTY FOREST PRESERVE DISTRICT (“**Tenant**”) a municipal corporation (hereinafter referred to as “**Tenant**”) whose address is 1899 West Winchester Road, Libertyville, IL 60073.

WHEREAS, Landlord is the owner of various parcels of land on or adjacent to the former rights-of-way of Lake County and more fully described on Exhibit A (“**Landlord’s Property**”);

NOW THEREFORE, Landlord, for and in consideration of the payment of Rent (as hereinafter defined) by Tenant, and of the covenants, conditions and agreements of Tenant hereinafter set forth, does hereby lease and demise to the Tenant (without warranty of title), and Tenant does hereby lease from Landlord, a portion of Landlord’s property located in Lake County, Illinois as shown on Exhibit A attached hereto and made a part hereof (the “**Leased Premises**”), for the purposes specified in Section 2 below.

**1. TERM.**

A. The term of this Lease (the “**Term**”) shall begin on February 1, 2024 (the “**Commencement Date**”) and shall terminate on January 31, 2044 unless sooner terminated as provided herein.

B. Subject to the terms and provisions of this Lease, Landlord hereby grants to Tenant one (1) option to renew this Lease on the same terms and conditions (each, a “**Renewal Option**”) for a renewal term of ten (10) years (each, a “**Renewal Term**”). If Tenant desires to exercise a Renewal Option, it shall notify Landlord in writing no earlier than one (1) year and not later than one hundred eighty (180) days prior to the then current expiration date of the Term (before the operation of the Renewal Option being exercised); and, once exercised, shall operate to extend the Term to end concurrently with the Renewal Term set by the Renewal Option so exercised.

C. Subject to Subsection 1.D. below, such notice shall only be effective if delivered at a time when Tenant is not in default hereunder and when to the knowledge of Tenant, no default, breach, unsatisfied condition or other event has occurred or circumstances exist that constitute or which, with the giving of notice or the passage of time (including the passage of time during which a default has occurred and has not yet been cured during any applicable grace period) or both, would constitute such a default.

D. In addition to any other inspections of the Leased Premises that Landlord may conduct during the Term of this Lease, during the period between the exercise of a Renewal Option and the start of the associated Renewal Term, Landlord shall review the Leased Premises and determine whether Tenant is in compliance with the terms and conditions of the Lease. Landlord shall notify Tenant in writing if any deficiencies in the performance of Tenant's obligations under the Lease are discovered during such review and any actions needed to correct them. Unless otherwise agreed in writing by Landlord, Tenant shall correct any item on such notice prior to the start of the Renewal Term in question.

E. Prior to the beginning of any Renewal Term, the parties shall execute an amendment to this Lease to memorialize such Renewal Term. If Tenant does not exercise a Renewal Option, such Renewal Option and all subsequent remaining Renewal Options (if any) shall thereupon expire.

2. **PURPOSE.** The Leased Premises shall be used by Tenant solely for the purposes of installing, operating, repairing and maintaining a 14-foot wide multi-use public trail for as shown on Exhibit "A-1", "A-2", "A-3" and "A-4" ("**Tenant's Facilities**"), in compliance with all Legal Requirements (as defined in the next sentence) and the terms and provisions of this Lease, and for no other purposes (the "**Permitted Use**"). For purposes hereof, the term "**Legal Requirements**" shall mean all present and future laws, rules, orders, ordinances, regulations, statutes, requirements, codes (including the National Electrical Safety Code), executive orders, court orders, rules of common law, and any judicial interpretations thereof, extraordinary as well as ordinary, of all governmental authorities, and all rules, regulations and government orders with respect thereto, and of any applicable fire rating bureau, or other body exercising similar functions, affecting the Leased Premises or the maintenance, use or occupation thereof, or any street, sidewalk or other property comprising a part thereof, regardless of whether imposed by their terms upon Landlord or Tenant, or the use and occupancy thereof by Tenant. "Legal Requirements" shall include "Environmental Laws" as defined in Section 15, below. Tenant's use of the Leased Premises shall also be and remain subject to Landlord's superior right to use all or any portion of the Leased Premises for its business purposes, including the installation, use and maintenance of any transmission, distribution or communications improvements, fixtures, facilities, machinery, equipment and/or other property owned by Landlord and now or hereafter installed by Landlord on or near the Leased Premises ("**Landlord's Facilities**").

3. **RENT.**

A. **Base Rent.** Landlord acknowledges its receipt of the payment of "**Base Rent**", a one-time payment by Tenant in the amount of One and No/100 Dollars (\$1.00) and no other Base Rent shall be assessed during the term of this Lease.

B. **Rent.** For purposes of this Lease, the term "**Rent**" shall mean the Base Rent, together with all other amounts due and payable by Tenant to Landlord under this Lease.

C. **Payment of Rent.** All Rent due and payable by Tenant under this Lease shall be paid to the following address:

Commonwealth Edison Company  
Real Estate Department, 4<sup>th</sup> Floor  
Three Lincoln Center  
Oakbrook Terrace, Illinois 60181  
Attn: Lease Payment Department

or to such other place as Landlord may from time to time designate in writing. All payments due from Tenant hereunder which are not paid when due shall bear interest at a rate equal to ten percent (10%) per annum from the date due until paid (the “**Default Rate**”). Such interest shall be compounded monthly. In addition to, and not in lieu of, the foregoing (and any other rights and remedies to which Landlord is entitled under this Lease), in the event that any payment due from Tenant hereunder is not paid within five (5) business days of the date that the same is due, then a late fee in the amount of ten percent (10%) of the unpaid amount shall be due and payable by Tenant to Landlord. All Rent shall be paid by Tenant without notice or demand, and without any set-off, counterclaim, abatement or deduction whatsoever, in lawful money of the United States by bank check or wire transfer of immediately available funds. Tenant’s obligations to pay Rent are independent of each and every covenant contained in this Lease.

E. Net Lease. Except as otherwise provided in this Lease, the Rent herein shall be absolutely net to Landlord, so that this Lease shall yield, net to Landlord, the Rent in each year during the Term of this Lease and any renewals thereof, and that all costs, expenses and obligations of every kind and nature whatsoever, relating to the Leased Premises which may arise or become due during the Term of this Lease or any renewal or extension thereof, or as a result of Tenant’s use or occupancy of the Leased Premises, shall be paid by Tenant, and Tenant agrees to indemnify, defend (with counsel acceptable to Landlord) and hold harmless Landlord from all such costs, expenses and obligations.

4. TAXES. Tenant shall pay the following amounts as “Taxes” to Landlord in each case no later than thirty (30) days after Landlord’s written demand therefor:

A Tenant’s proportionate share of the land component of all real estate taxes for each tax parcel of which the Leased Premises is a part for all periods falling within the Term, which proportionate share shall be calculated as follows: (i) the total land component of each tax bill for each such real estate tax parcel which includes any portion of the Leased Premises, multiplied by (ii) a fraction, the numerator of which shall be the acreage of the portion of such tax parcel which falls within the Leased Premises, and the denominator of which shall be the total acreage of such tax parcel; plus

B All real estate taxes and other assessments which are allocable to any improvements, structures or fixtures constructed, installed, or placed by Tenant at the Leased Premises for all periods falling within the Term, plus

C Any increase in the real estate taxes and other assessments payable with respect to the Leased Premises (or any tax parcel of which the Leased Premises is a part) which is allocable to this Lease, Tenant’s use or occupancy of the Leased Premises, or any improvements, structures or fixtures constructed, installed or placed by Tenant at the Leased Premises (but without duplication of any amount payable pursuant to clause (B) above), for all periods falling within the Term; plus

D For purposes of this Lease, Taxes “for” or “with respect to” any particular period (or portion thereof) shall mean the Taxes which are payable during the calendar year in which any portion of such period falls, irrespective of the fact that such Taxes may have accrued with respect to a different period.

D Tenant hereby covenants and agrees that Tenant shall, no later than the Tax Exemption Date (as hereinafter defined), at Tenant’s sole cost and expense, execute and deliver all documents,

instruments petitions and applications, and take all other actions which may be reasonably necessary and/or appropriate, in order to cause the Leased Premises to be exempted from the payment of real estate taxes, to the extent that it is possible without the transfer of any ownership or change in the property owner name in the records of the applicable taxing jurisdiction, under applicable Legal Requirements. Concurrently with the delivery of any such documents, instruments, petitions and applications, Tenant shall furnish Landlord with copies thereof. In the event that Tenant is successful in obtaining any such real estate tax exemption for the Leased Premises, then Tenant shall thereafter cause such real estate tax exemption to be continued for each tax year (or portion thereof) during which this Lease is in effect (and Tenant shall execute such documents, instruments, petitions and applications, and take such other actions which may be reasonably necessary and/or appropriate, to cause such property tax exemption to be so continued). In the event that Tenant is unsuccessful in obtaining or continuing any such real estate tax exemption with respect to the Leased Premises, then Tenant shall thereafter use commercially reasonable efforts to continue to seek such exemption (or continuance thereof, as applicable) and shall, from time to time if Landlord so requests, take such actions as may be reasonably necessary to apply for such exemption (or continuation); provided however, in no event shall Tenant have any power or authority to change, alter or modify in any way, the tax parcel number, property owner name or mailing address of the Leased Premises in the records of the applicable taxing jurisdiction. For purposes hereof, the term "Tax Exemption Date" shall mean the date that is the earlier of: (i) sixty (60) days after the date of this Lease, or (ii) the deadline for submitting a real estate tax exemption petition or application for the real estate taxes for the year in which this Lease is executed and delivered. Notwithstanding anything contained in this paragraph, to the extent Tenant fails to obtain a tax exemption with respect to the Leased Premises for any reason, Tenant shall pay the Taxes as required above in this Section 4.

**5. CONDITION.** Tenant has examined the Leased Premises and knows its condition. Tenant hereby accepts the condition of the Leased Premises in its **AS-IS, WHERE-IS CONDITION, WITH ALL FAULTS**. No representations or warranties as to the condition, repair or compliance with Legal Requirements thereof, and no agreements to make any alterations, repairs or improvements in or about the Leased Premises have been made by or on behalf of Landlord. By accepting possession of the Leased Premises, Tenant shall be conclusively presumed to have accepted the condition thereof and to have unconditionally waived any and all claims whatsoever related to the condition of the Leased Premises.

**6. MAINTENANCE; SERVICES AND UTILITIES.**

A. Tenant agrees at its sole cost and expense, to keep and maintain **the Leased Premises together with the [adjacent] open grass way area (such open grass way area together with Tenant's Facilities being the "Specified Area")**] in a clean, safe, neat, sanitary and sightly condition and repair, and commensurate with the conditions existing at the time this Lease is executed to Landlord's satisfaction at all times during the Term hereof. Without limiting the generality of the foregoing, Tenant shall (subject to the terms and provisions of this Lease and all at Tenant's sole cost and expense): (i) perform any and all necessary paving, grading, landscaping, cutting and mowing of grass and weeds (including all Canadian thistles and other noxious weeds and growths at the Leased Premises) and snow and ice removal, and (ii) promptly (and if Landlord provides written notice, no later than three (3) business days after receipt of such notice) remove all litter, garbage and graffiti from, and repair any vandalism (except for vandalism to Landlord's Facilities) to, the Specified Area or any nearby area, including, without limitation, any structure or bridge crossing used for Tenant's Facilities, on or near the Specified Area. Tenant's obligations under this Section 6 are solely those of Tenant and Landlord shall have no responsibility to undertake such obligations or to perform any action required of Tenant hereunder.

B. Landlord shall not be responsible for furnishing or providing any services or utilities to the Leased Premises (or any costs or expenses associated therewith), but rather, Tenant shall be responsible, at Tenant's sole cost and expense, for providing all such services and utilities. Landlord has made no



representation, warranty or covenant of any kind regarding the availability (or future availability) of any such utilities and services, and no failure to provide or interruption of any such services or utilities or services shall give rise to any right or remedy in favor of Tenant under this Lease. Landlord may from time to time, but shall have no obligation to, maintain the Leased Premises in accordance with its customary maintenance program then in effect and Tenant shall have no right to require Landlord to maintain the Leased Premises in any manner.

C. Tenant assumes all of the responsibilities normally identified with the ownership of the Leased Premises, including, but not limited to, responsibility for the condition of the Leased Premises, such as the operation, repair, replacement, maintenance and management of the Leased Premises, including, without limitation, repairs to all buildings, structures, fixtures, equipment and other property thereon; provided, that (except as expressly set forth below) in no event shall Tenant maintain, repair, gain access to or in any way use or operate any of Landlord's Facilities.

7. **SURRENDER OF LEASED PREMISES; RESTORATION.** Tenant agrees that upon termination of the Term of this Lease, whether by expiration or otherwise, Tenant will peaceably quit and surrender the Leased Premises to Landlord, and will, at its sole cost and expense, remove all Tenant's personal property, fixtures, structures and improvements, and will, at Landlord's sole and absolute discretion, restore and regrade the Leased Premises to substantially the same condition the Leased Premises were in on the date hereof (other than any improvements, installations and modifications made by Landlord). This Section shall survive the termination or expiration of the Lease.

8. **COMPLIANCE WITH LAWS; WASTE; OTHER COVENANTS OF TENANT.**

A. General. Tenant, at its sole expense, shall comply, and cause the Leased Premises to comply, with all Legal Requirements, Landlord's vegetation management practices and procedures and all of the requirements listed in Exhibits C-1 and C-2 attached to this Lease and made a part hereof. In addition, Tenant covenants and agrees that it will not commit waste, loss or damage to the Leased Premises or any other property of Landlord.

B. Change in Law. Tenant acknowledges that Landlord may incur costs as a result of the enactment of new Legal Requirements relating to the Leased Premises, and/or changes in Legal Requirements relating to the Leased Premises. Tenant agrees that any such costs incurred by Landlord for complying with such new or changed Legal Requirements and due in whole or in part to Tenant's use and/or occupancy of the Leased Premises shall be an expense recoverable by Landlord from Tenant. To the extent any such expense paid by Tenant to Landlord is subsequently recovered by or reimbursed to Landlord through insurance or recovery from responsible third parties or other action, Tenant shall be entitled to a proportionate share (as reasonably determined by Landlord) of such recovery or reimbursement.

C. Notice of Violations. Tenant shall immediately provide Landlord with written notice: (i) upon Tenant's obtaining knowledge of any potential or known violations of any Legal Requirements relating to the Leased Premises, and/or (ii) of Tenant's receipt of any notice, correspondence, demand or communication of any nature from any governmental authority related to the Leased Premises, including without limitation, any alleged or actual violation of any Legal Requirements or any request for additional information, rejection or confirmation regarding any application for exemption from real estate taxes.

D. Height and Other Limitations. No vehicles, equipment or anything else (including, but not limited to, any equipment attached to vehicles or equipment such as antennas, and/or any trees, shrubs or other plants or vegetation planted or installed per Exhibit E at the Leased Premises by Tenant) having a height which exceeds the maximum allowable height under OSHA's height standards in effect from time

to time during the Term, shall be driven, moved or transported on the Leased Premises without Landlord's prior written consent. Tenant shall not allow any activity which could result in a wire to ground electrical contact or damage to towers or poles; such as, flying kites, model airplanes, driving minibikes, go carts and snowmobiles. If Landlord so requests, Tenant will post signs prohibiting such activities.

## 9. ALTERATIONS.

A. Generally. Tenant shall not make any alterations, installations, improvements, additions or other physical changes (collectively, the "**Alterations**") in or about the Leased Premises without Landlord's prior written consent in each instance, which consent may be granted or denied by Landlord in its sole and absolute discretion. Any Alterations shall be performed: (i) by Tenant, at Tenant's sole cost and expense (and Landlord shall have no duty or obligation with respect thereto), (ii) pursuant to plans and specifications approved in writing by Landlord (in Landlord's sole discretion), (iii) by contractors and subcontractors approved in writing by Landlord (in Landlord's sole discretion), (iv) in compliance with all Legal Requirements, and (v) in a good and workmanlike manner, free of all liens. Tenant shall, at Tenant's sole cost and expense, obtain any and all permits and approvals necessary for the performance of any Alterations. During the performance of any Alterations, Tenant shall carry, and shall cause its contractors and subcontractors to carry, such insurance as Landlord shall, in its sole discretion, direct. Neither Tenant nor any of Tenant's authorized agents shall, at any time prior to or during the Term, directly or indirectly, employ, or permit the employment of, any contractor, mechanic or laborer in the Leased Premises, or permit any materials to be delivered to or used in the Leased Premises, whether in connection with any Alteration or otherwise, if, in Landlord's sole judgment, such employment, delivery or use will interfere or cause any conflict with other contractors, mechanics or laborers engaged in the construction, maintenance or operation of the Leased Premises (or any other property) by Landlord, Tenant or others, or the use and enjoyment of the Leased Premises by Landlord or other tenants or occupants of the Leased Premises. In the event of such interference or conflict, upon Landlord's request, Tenant shall cause all contractors, mechanics or laborers causing such interference or conflict to leave the Leased Premises immediately. At the sole discretion of Landlord, any proposed Alterations shall be subject to a review fee, the amount of which will be determined by Landlord upon receipt of Tenant's request for consent to such Alterations. Such fee shall be due and payable by Tenant within five (5) days from receipt of notice from Landlord of the amount of such review fee and Landlord shall not be required to consider Tenant's request for Landlord's consent to any Alterations until the review fee for such Alterations is paid.

B. Paving, Filling and Planting. Without limiting the generality of the terms and provisions of Subsection 9.A. above, Tenant acknowledges and confirms that any and all grading, leveling, adding or removing soil and/or paving of the Leased Premises (or any portion thereof), and any and all planting, seeding and similar activities shall constitute "**Alterations**" for purposes of this Lease, and shall be subject to each and all of the terms and provisions relating thereto. In any event, any and all debris from any Alterations of Tenant shall be promptly removed from the Leased Premises by Tenant. In the event that, in connection with Tenant's Alterations, Tenant elects to fill any low spots on the Leased Premises, only clean fill (defined as not containing debris such as gravel, concrete, tree roots, brick or any contaminants) shall be used prior to the spreading of base fill underlying any paving. No paving or grading work (or similar work) of any kind will be undertaken within a ten (10) foot radius of any tower leg (or similar equipment, improvement or facility) of Landlord. Paving shall be well drained, firm and solid blacktop (or other substance approved in writing by Landlord), and shall be neat and clean in appearance. In addition, and not in lieu of the foregoing, any such grading, leveling, paving, filling and/or planting or seeding of the Leased Premises shall comply with the terms and provisions of Section 12 below and Landlord's vegetation management practices and procedures. Tenant shall not cause or permit the existing ground grade on the Leased Premises to be increased or decreased without Landlord's prior written consent.

C. Drainage. Tenant covenants and agrees that no Alterations made by Tenant pursuant to this Lease shall cause any surface water drainage problems for Landlord or any adjoining landowners. In the event that any such water drainage problems are caused by Tenant's Alterations, Tenant shall correct such problems immediately at Tenant's sole cost and expense.

D. Fencing and Barriers. Tenant covenants and agrees that, in the event that Tenant installs (or is required (by Landlord or otherwise) to install) any fencing and/or gates in connection with Tenant's Alterations at the Leased Premises (or its use or occupancy of the Leased Premises), Tenant will install, maintain and operate such fences and/or gates in strict compliance with the requirements of Exhibits C-1 and C-2, attached hereto and made a part hereof, and any and all other fencing and locking rules, regulations and guidelines which Landlord may deliver to Tenant from time to time prior to or during the Term. Tenant also acknowledges and confirms that, in connection with Landlord's review and/or approval of the plans and specifications for Tenant's Alterations at the Leased Premises (as provided in Subsection 9.A. above), Landlord may require, prior to or at any time during the Term of this Lease, that barriers ("**Barriers**") be installed on the Leased Premises in order to protect Landlord's Facilities and/or other equipment, improvements and facilities of Landlord and other users and occupants of the Leased Premises. Any such Barriers shall be installed, at Landlord's sole option, either: (i) by Tenant, at Tenant's sole cost and expense, in a manner satisfactory to Landlord, or (ii) by Landlord, in which event Tenant shall pay to Landlord, prior to such installation, Landlord's reasonable estimate of the cost of such installation of the Barriers. Any barriers required to be installed hereunder shall be installed, maintained and operated by Tenant in strict compliance with the requirements of Exhibits C-1 and C-2, attached hereto, and any and all rules, regulations and guidelines regarding barriers which Landlord may deliver to Tenant from time to time prior to or during the Term.

E. Soil Removal. Tenant hereby agrees that it will not remove any soil from the Leased Premises without the prior written consent of Landlord. Any soil removed from the Leased Premises to which Landlord consents (as provided in the preceding sentence) shall become the property of Tenant and shall be: (i) transported and disposed of by Tenant (at its sole cost and expense) in a manner approved in writing by Landlord and in compliance with all Legal Requirements, and (ii) promptly replaced by Tenant at its sole cost and expense, with clean soil not contaminated with Hazardous Materials (as defined in Section 15 below).

F. Third Party Facilities. Tenant hereby acknowledges that the Leased Premises may be used from time to time to accommodate equipment and facilities of other persons and/or entities (including, without limitation, pipeline and utility companies) which are (or will be) located on, above or below the surface of the Leased Premises. Tenant agrees that it will contact any such persons and/or entities holding rights to use and/or occupy the Leased Premises, and provide the proper protection reasonably required by such persons or entities, in connection with Tenant's use and occupancy of the Leased Premises. Tenant further agrees to furnish Landlord copies of the correspondence between any such persons or entities and Tenant. Tenant agrees that this requirement shall apply to any installations currently located at the Leased Premises and any and all future installations within the Leased Premises.

G. Supervision. Landlord shall have the right (but not the obligation) to monitor and observe Tenant's performance of any Alterations at the Leased Premises (or any component thereof) and, in the event that Landlord so elects, Tenant shall reimburse Landlord for any and all costs of such monitoring and observation, together with a charge for Landlord's overhead, as determined by Landlord. In the event that Landlord elects to monitor or observe any such work, in no event shall Landlord be deemed to have approved or made any representation or warranty regarding the same.

H. Notification. In addition to and not in lieu of, Tenant's other obligations under this Section 9, Tenant also agrees to notify Landlord's Representative, at Telephone Number 866 340-2841, at least seventy-two (72) hours prior to the commencement of any Alterations at the Leased Premises.

10. INDEMNITY. To the maximum extent permitted under Legal Requirements, Tenant agrees to protect, indemnify, defend (with counsel acceptable to Landlord) and hold harmless Landlord and Exelon Corporation, a Pennsylvania corporation, and their respective parents, subsidiaries and affiliates, and their respective officers, directors, shareholders, employees, representatives, agents, contractors, licensees, lessees, guests, invitees, successors and assigns (collectively, the "**Indemnified Parties**") from and against any and all losses, costs, damages, liabilities, expenses (including, without limitation, reasonable attorneys' fees) and/or injuries (including, without limitation, damage to property and/or personal injuries) suffered or incurred by any of the Indemnified Parties (regardless of whether contingent, direct, consequential, liquidated or unliquidated) (collectively, "**Losses**"), and any and all claims, demands, suits and causes of action brought or raised against any of the Indemnified Parties (collectively, "**Claims**"), arising out of, resulting from, relating to or connected with: (i) any act or omission of Tenant or its officers, directors, shareholders, employees, representatives, agents, contractors, licensees, lessees, guests, invitees, successors and assigns (collectively, "**Tenant Group**") at, on or about the Leased Premises, and/or (ii) any breach or violation of this Lease on the part of Tenant, and notwithstanding anything to the contrary in this Lease, such obligation to indemnify, defend and hold harmless the Indemnified Parties shall survive any termination or expiration of this Lease. This indemnification shall include, without limitation, claims made under any workman's compensation law or under any plan for employee's disability and death benefits (including, without limitation, claims and demands that may be asserted by employees, agents, contractors and subcontractors).

11. WAIVER. Any entry onto the Leased Premises by Tenant and, to the extent permitted by law, each and every member of the Tenant Group, shall be at such parties' sole risk, and Landlord makes (and has heretofore made) no representations or warranties of any kind whatsoever regarding the Leased Premises or the condition of the Leased Premises (including, without limitation, the environmental condition thereof). To the fullest extent permitted by law, Tenant and each member of the Tenant Group hereby waives any and all claims, demands, suits and causes of action against the Indemnified Parties, and fully and forever releases the Indemnified Parties, for any loss, cost, damage, liability or expense (including, without limitation attorneys' fees) suffered or incurred by Tenant or any member of the Tenant Group in connection with any entry onto the Leased Premises pursuant to this Lease. Without limiting the generality of the foregoing, in no event shall any of the Indemnified Parties be responsible or liable for any loss, damage, destruction, theft or misappropriation of any of the property of Tenant or any member of the Tenant Group. This Section will survive termination or expiration of the Lease.

12. DIGGING WORK. If Tenant performs any grading, leveling, digging or excavation work on the Leased Premises (which work shall be subject to Landlord's prior written approval), Tenant will notify J.U.L.I.E. at telephone number (800) 892-0123, C.U.A.N. at (312) 744-7000 if the Leased Premises are located in the City of Chicago, or in the event the Leased Premises are located outside J.U.L.I.E.'s or C.U.A.N.'s jurisdiction, any other services required by the utilities in the jurisdiction, at least seventy-two (72) hours prior to the commencement of such work in order to locate all existing utility lines that may be present on the Leased Premises. If Tenant damages any such underground facilities in the course of its work, Tenant will promptly reimburse Landlord or the owner of such equipment or facilities for any and all expense incurred in repairing or replacing such damage.

13. CASUALTY. In the event of any damage to or destruction of the Leased Premises, by fire or other casualty, which materially and adversely affects Tenant's use and enjoyment of the Leased Premises for the purposes specified in this Lease, then either Landlord or Tenant shall have the right, no later than ninety (90) days after such party becomes aware of such damage or destruction, to terminate this Lease

upon sixty (60) days' prior written notice to the other. In the event of any damage or destruction which is not so extensive, or in the event that Landlord and Tenant elect not to terminate this Lease pursuant to the preceding sentence, then this Lease shall continue in full force and effect, and Tenant will promptly and diligently, at its sole cost and expense, repair, restore, rebuild and replace the Leased Premises (and all improvements, fixtures, equipment and property thereat) as nearly as possible to the condition they were in immediately prior to such damage or destruction. Any such work shall be done in a manner satisfactory to Landlord, and in accordance with all Legal Requirements and the terms and provisions of this Lease. Landlord shall not be liable or responsible for any loss or damage caused to any property of Tenant or any member of the Tenant Group (including, without limitation, any such loss or damage caused by fire, vandalism or other casualty) at any time during the Term hereof.

**14. CONDEMNATION.** If the Leased Premises, or a substantial part thereof, or a portion which prevents use of the Leased Premises for the purposes specified herein, shall be taken or condemned by any competent authority for any public use or purpose, the Term shall end on the date when the possession of the part so taken shall be required for such use or purpose, and without apportionment of any condemnation award or proceeds (it being understood that Landlord shall be entitled to the entire amount of any such award or proceeds, and Tenant shall have no right to share therein). Then current Rent shall be apportioned as of the date of such termination.

**15. ENVIRONMENTAL PROTECTION.**

A. General. Tenant covenants and agrees that Tenant shall conduct its operations on the Leased Premises in compliance with all applicable Environmental Laws (as hereinafter defined) and further covenants that neither Tenant nor any member of the Tenant Group shall use, bring upon, transport, store, keep or cause or allow the discharge, spill or release (or allow a threatened release) in each case of any Hazardous Materials (as hereinafter defined) in, on, under or from the Leased Premises. Without limiting any other indemnification obligations of Tenant contained herein, Tenant hereby agrees to protect, indemnify, defend (with counsel acceptable to Landlord) and hold harmless the Indemnified Parties from and against any and all Losses and Claims (including, without limitation, (i) reasonable attorneys' fees, (ii) liability to third parties for toxic torts and/or personal injury claims, (iii) fines, penalties and/or assessments levied or raised by any governmental authority or court, and (iv) assessment, remediation and mitigation costs and expenses and natural resource damage claims) arising out of, resulting from or connected with any Hazardous Materials used, brought upon, transported, stored, kept, discharged, spilled or released by Tenant, any member of the Tenant Group or any other person or entity (except for any person or entity which is an Indemnified Party) in, on, under or from the Leased Premises. For purposes of this Lease, the term "**Hazardous Materials**" shall mean all toxic or hazardous substances, materials or waste, petroleum or petroleum products, petroleum additives or constituents or any other waste, contaminant or pollutant regulated under or for which liability may be imposed by any Environmental Law. For purposes hereof, the term "**Environmental Laws**" shall mean all federal, provincial, state and local environmental laws, statutes, ordinances, regulations and other requirements (including common law) regulating or imposing standards of care with respect to the handling, storage, use, emitting, discharge, disposal or other release of Hazardous Materials, including, but not limited to, the Resource Conservation and Recovery Act of 1976, 42 U.S.C. §§ 6901 et seq., the Clean Air Act, 42 U.S.C. §§7401, et seq., the Federal Water Pollution Control Act, 33 U.S.C. §§1251, et seq., the Emergency Planning and Community Right to Know Act, 42 U.S.C. §§ 1101, et seq., the Comprehensive Environmental Response, Compensation and Liability Act of 1980, 42 U.S.C. §§ 9601 et seq., the Toxic Substances Control Act, 15 U.S.C. §§2601, et seq., the Oil Pollution Control Act, 33 U.S.C. §§2701, et seq., any successor statutes to the foregoing, or any other comparable local, state or federal statute or ordinance pertaining to protection of human health, the environment or

natural resources, including without limitation the preservation of wetlands, and all regulations pertaining thereto, as well as applicable judicial or administrative decrees, orders or decisions, authorizations or permits.

B. Wetlands. If there are wetlands on the Leased Premises, or if wetlands should develop on the Leased Premises during the Term, Tenant shall strictly comply with and observe all applicable Environmental Laws. At Landlord's request, Tenant shall, at Tenant's sole cost, furnish Landlord with a survey of the Leased Premises delineating any wetland areas located on the Leased Premises. Under no circumstances shall Tenant change the physical characteristics of any wetland areas located on the Leased Premises, or any other adjoining land or place any fill material on any portion of the Leased Premises, or any adjoining land, without in each instance obtaining Landlord's prior written consent (which may be granted or withheld in Landlord's sole discretion), and only then in compliance with applicable Environmental Laws.

C. Notice of Violation/Release. Tenant shall provide Landlord with prompt written notice upon Tenant's obtaining knowledge of the existence of any Hazardous Materials on, in or under the Leased Premises in violation of Environmental Laws, or of any potential or known release or threat of release of any Hazardous Materials affecting the Leased Premises.

D. Survival. This Section shall survive the expiration or other termination or expiration of the Lease.

**16. INSURANCE**. Tenant shall comply with the insurance provisions contained in Exhibit D attached hereto and made a part hereof.

**17. ZONING**. Tenant hereby acknowledges that Landlord has made no representations that the Leased Premises may be used or is properly zoned for the Permitted Use, and Tenant further agrees that it will (at its sole cost and expense) obtain all necessary permits and other approvals prior to undertaking the Permitted Use. Tenant assumes all obligations and responsibilities for compliance with all Legal Requirements including, without limitation, all applicable zoning laws and ordinances, building codes and governmental regulations. This Lease is not preconditioned on Tenant obtaining any zoning or use permits or approval. This Lease does not constitute the authority to seek a zoning change to permit the Permitted Use, and in no event shall Tenant seek or apply for any such zoning change to the Leased Premises without Landlord's prior written consent, which consent may be given or withheld in Landlord's sole and absolute discretion.

**18. NO SIGNS**. Tenant shall not place or permit to be placed by any person or entity (other than Landlord) on the Leased Premises any signs or billboards (including, without limitation, any advertising signs or billboards) without the prior written approval of Landlord, which approval Landlord may give or withhold in Landlord's sole and absolute discretion. Tenant may place signs on the Specified Area without the consent of Landlord relating solely to safety and directional matters involving the Permitted Use. Tenant agrees to place a sign in a visible area within the Specified Area that contains an acknowledgment of Landlord's assistance and cooperation with the Tenant with respect to the Permitted Use, all in a manner and form reasonably acceptable to Landlord.

**19. DAMAGE TO LANDLORD'S FACILITIES**. Tenant agrees that in the event any work done by or on behalf of the Tenant on the Leased Premises causes damage to Landlord's Facilities, Tenant will promptly reimburse Landlord for any and all expense incurred for the repairing or replacement of such damage, within thirty (30) days, after presentation to Tenant of Landlord's statement therefor.

**20. DEFAULT**.

A. The occurrence of any of the following shall be considered a “**Default**”:

(i) Tenant shall at any time fail to make any payment of Rent (or any portion thereof) or any other payments required of Tenant hereunder when required, and such failure continues for a period of more than ten (10) days (without necessity of any notice or demand therefor); or

(ii) Tenant shall breach or violate any of its duties or obligations set forth in Section 7 (Surrender of Leased Premises; Restoration), Section 8 (Compliance with Laws), Section 16 (Insurance), Section 22 (Covenants Against Liens), Section 23 (Assignment and Subletting) or Section 30 (Subordination; Estoppel) of this Lease; or

(iii) Tenant shall at any time be in default of any other covenants and conditions of this Lease to be kept, observed and performed by Tenant, which and such default continues for more than thirty (30) days (or such shorter time period as may specifically be set forth in this Lease) after notice from Landlord; or

(iv) this Lease or Tenant’s interest therein, or any interest in Tenant, shall be assigned, transferred, mortgaged or pledged, levied on or attempted to be taken by execution, attachment or other process of law, or if any execution or attachment shall be issued against Tenant, or any of Tenant’s property in the Leased Premises shall be taken or occupied or attempted to be taken or occupied by someone other than Tenant; or

(v) a receiver, assignee or trustee shall be appointed for Tenant or Tenant’s property or if the Tenant shall file bankruptcy, or if involuntary bankruptcy proceedings shall be filed against Tenant; or

(vi) Landlord shall receive notice of any alleged violation of any Legal Requirements resulting from or in any way connected with Tenant’s use of the Leased Premises and such violation is not cured (and all liabilities connected therewith fully satisfied) by Tenant prior to the earlier of (a) the last day of the period permitted by law for curing such violation or (b) the first date Landlord becomes subject to any fine, penalty, lien, judgment, order or other liability due to the continued existence of such violation; or

(vii) Tenant shall abandon the Leased Premises or vacate same during the Term hereof.

B. If a Default occurs, Landlord may do any or all of the following (all of which remedies shall be cumulative and not exclusive, and all of which remedies shall be in addition to, and not in lieu of, any other rights and remedies to which Landlord may be entitled under this Lease, at law or in equity):

(i) At its option, at once, without notice to Tenant or to any other person, terminate this Lease and at its option, require payment in full of the Rent due for the unexpired term of the Lease;

(ii) Enter into the Leased Premises, and remove Tenant’s property and effects therefrom, and/or take and hold possession thereof, without such entry and/or possession terminating this Lease or releasing Tenant in whole or in part from Tenant’s obligations to pay Rent and perform all its other obligations hereunder for the full Term, and to relet the Leased Premises or any part or parts thereof, either in the name of for the account of Landlord or Tenant, for such Rent and for such term and terms as Landlord may see fit, which term may at Landlord’s option extend beyond the balance of the Term of this Lease. Except to the extent required under applicable Legal Requirements, Landlord shall not be required to accept any tenant offered by Tenant or to observe any instructions given by the Tenant about such reletting. In any case, Landlord may make such repairs, alterations and additions in or to the Leased Premises as it sees fit. Tenant shall pay

Landlord any deficiency between the Rent hereby reserved and covenanted to be paid and the net amount of the rents collected on such reletting, for the balance of the Term of this Lease, as well as any expenses incurred by Landlord in such reletting, including, but not limited to attorney's fees, broker fees, the expenses of repairing, altering the Leased Premises, and otherwise preparing the same for re-rental. All such costs, other than the rental, shall be paid by Tenant upon demand by Landlord. Any deficiency in rental amounts shall be paid in monthly installments, upon statements rendered by Landlord to Tenant, unless Landlord has declared the entire Rent for the balance of the Term due, as elsewhere in this Lease provided. Any suit brought to collect the amount of the deficiency for any one or more months' Rent shall not preclude any subsequent suit or suits to collect the deficiency for any subsequent month's Rent;

(iii) Require that upon any termination of this Lease, whether by lapse of time, the exercise of any option by Landlord to terminate the same, or in any other manner whatsoever, or upon any termination of Tenant's right to possession without termination of this Lease, the Tenant shall at once surrender possession of the Leased Premises to the Landlord and immediately vacate the same and remove all effects therefrom, except such as may not be removed under other provisions of this Lease. If Tenant fails to do so, Landlord may forthwith re-enter the Leased Premises, with or without process of law, and repossess itself thereof as in its former estate and expel and remove Tenant and any other persons and property therefrom, using such force as may be necessary without being deemed guilty of trespass, eviction or forcible entry, without thereby waiving Landlord's rights to Rent or any other rights given Landlord under this Lease or at law or in equity;

(iv) Remove, at its option if the Tenant shall not remove all effects from the Leased Premises in this Lease as provided, any or all of such effects in any manner that Landlord shall choose and store the same without liability for loss thereof, and Tenant will pay Landlord, upon demand, any and all expenses incurred in such removal and also storage of said effects for any length of time during which the same shall be in Landlord's possession or in storage, or Landlord may at its option, without notice, sell any or all of said effects in such manner and for such price as the Landlord may deem best and apply the proceeds of such sale upon any amounts due under this Lease from the Tenant to Landlord, including the expenses of removal and sale;

(v) Collect from Tenant any other loss or damage Landlord may sustain by reason of any breach (including, without limitation, the unamortized portion of any brokerage fee or commission paid by or on behalf of Landlord to any broker or finder with respect to this Lease) and any diminished value of the Leased Premises resulting from said breach;

(vi) Enjoin any such breach of this Lease by Tenant; and/or

(vii) Take any and all corrective actions Landlord deems necessary or appropriate to cure the default of Tenant in question and charge the cost thereof to Tenant, together with (i) interest at the Default Rate, and (ii) an administrative charge in an amount equal to ten percent (10%) of the cost of the corrective action to defray part of the administrative expense incurred Landlord in administering such cure, such payment to be made by Tenant upon Landlord's presentment and demand therefor.

C. Except as specifically provided in this Section Tenant expressly waives the service of any notice of intention to terminate this Lease or to terminate Tenant's right of possession of the Leased Premises or to re-enter the Leased Premises and waives the service of any demand for payment of Rent or for possession and waives the service of any and every other notice or demand prescribed by any statute, law or ordinance and agrees that the simple breach of any of the covenants of this Lease (beyond any applicable notice and cure periods) shall, of itself, without the service of any additional notice or demand



whatsoever, at Landlord's option, constitute a default on the part of Tenant. No receipt of monies by the Landlord from or for the account of Tenant or from anyone in possession or occupancy of the Leased Premises after termination in any way of this Lease or after the giving of any notice, shall reinstate, constitute or extend the Term of this Lease or affect any notice given to the Tenant prior to the receipt of such money, it being agreed that after the service of notice of the commencement of a suit, or after final judgment for possession of the Leased Premises, Landlord may receive and collect any Rent or other amounts due Landlord and such payment not waive or affect said notice, said suit, or said judgment.

D. Any and all rights and remedies which Landlord may have under this Lease at law or in equity, shall be cumulative and shall not be deemed inconsistent with each other, and any two or more or all of said rights and remedies may be exercised at the same time or at different times and from time to time.

E. If Landlord is required to incur expense, legal, incidental, or consequential, because of the breach of this Lease by Tenant, the Tenant shall promptly reimburse Landlord for such expense upon being given a written itemization and explanation thereof. In the event of commencing a court action as a result of any breach, it is agreed that such expenses are to be considered a part of the damages claimed in said action and any expense incurred in prosecuting that action shall be included. It is agreed that the term "expenses" as used herein shall include, but not be limited to, attorney's fees, court costs, district justice costs, and any and all other costs and expenses reasonably related to such breach.

F. The failure of Landlord to enforce rights under this Lease on one or numerous occasions shall not affect the Landlord's ability to enforce that right on any subsequent occasion or occasions.

G. Upon the occurrence of a Default or any breach or default under this Lease by Tenant, Tenant shall be liable for and shall reimburse Landlord upon demand for all reasonable attorney's fees and costs incurred by Landlord in enforcing Tenant's obligations under this Lease, whether or not Landlord files legal proceedings in connection therewith.

H. In the event that a Default shall occur, and Landlord elects to terminate this Lease, or upon expiration of this Lease, Tenant shall not be relieved of its duties or obligations under this Lease so long as Tenant or any of Tenant's property remains on the Leased Premises. Additionally, any rights and obligations created under or by this Section shall survive termination or expiration of this Lease.

I. In the event of a threatened breach by Tenant of any of the covenants or provisions of this Lease, Landlord shall (without limiting any of Landlord's other rights or remedies hereunder, at law or in equity) have the right to enjoin any such threatened breach.

**21. LIMITATION ON LIABILITY.** It is expressly understood and agreed by Tenant that none of Landlord's covenants, undertakings or agreements continued in this Lease are made or intended as personal covenants, undertakings or agreements by Landlord or any entity which is affiliated with Landlord its parent or subsidiaries. Tenant specifically agrees to look solely to Landlord's interest in the Leased Premises for the recovery of any sums, damages, awards or judgments from Landlord. It is agreed that neither Landlord, nor any entity which is affiliated with Landlord (nor any of their respective parents or subsidiaries, nor any of their respective shareholders, venturers, officers, directors or employees) shall be personally liable for any such sums, damages, awards or judgments. This Section will survive termination or expiration of the Lease.

**22. COVENANTS AGAINST LIENS.** Tenant hereby covenants and agrees that it will not cause or permit any lien (including, without limitation, any mechanic's lien) or claim for lien to be asserted against the Leased Premises or any interest therein, whether such lien or claim for lien results from or arises out of

any act or omission of Tenant or any member of the Tenant Group or otherwise. In the event any such lien or claim for lien is filed, Tenant will immediately pay and release the same. In the event such lien or claim of lien is not released and removed within five (5) days after notice from Landlord, Landlord, at its sole option and in addition to any of its other rights and remedies, may take any and all action necessary to release and remove such lien or claim of lien (it being agreed by Tenant that Landlord shall have no duty to investigate the validity thereof), and Tenant shall promptly upon notice thereof reimburse Landlord for all sums, costs and expenses, including court costs and reasonable attorneys' fees and expenses, incurred by Landlord in connection with such lien or claim of lien. Tenant hereby agrees to indemnify, defend and hold harmless Landlord from and against any and all liens or claims for lien arising out of or in any way connected with Tenant's use and occupancy of the Leased Premises. Any rights and obligations created under or by this Section shall survive termination or expiration of this Lease.

**23. ASSIGNMENT AND SUBLETTING.** Tenant shall not, directly or indirectly, assign, mortgage, pledge, encumber, or otherwise transfer this Lease (or any interest of Tenant herein), whether by operation of law or otherwise, and shall not sublet (or underlet), or permit, or suffer the Leased Premises or any part thereof to be used or occupied by others, without Landlord's prior written consent in each instance, which consent may be granted or denied by Landlord in its sole and absolute discretion. Any assignment, sublease, mortgage, pledge, encumbrance or transfer by Tenant in contravention of the provisions of this Section shall be void. For purposes of this Lease any transfer, directly, indirectly or by operation of law, of a "controlling" interest in Tenant shall constitute an assignment of this Lease, and shall be subject to the terms and provisions of this Section. For purposes hereof, a "controlling" interest in Tenant shall mean: (a) the ownership, directly or indirectly, of a majority of the outstanding voting stock or interests of Tenant, or (b) the possession, directly or indirectly, of the power to direct or cause the direction of the management and policies of Tenant, whether through the ownership of voting securities or other ownership interests, by statute, or by contract.

**24. TERMINATION.** Prior to the end of the Term, this Lease may be terminated at any time by either of the parties hereto by giving ninety (90) days prior written notice to the other party of such termination. This Lease may also be terminated by Landlord, if Landlord is required to do so by a regulatory body, by a court of competent jurisdiction or Legal Requirements. In the event this Lease is terminated for any reason, any Rent paid in advance shall be prorated to the effective date of such termination and the unearned portion thereof refunded to Tenant.

**25. LANDLORD'S RIGHTS.** The rights of the Landlord to utilize the Leased Premises in its utility business, at all times, will be and remain paramount to the rights herein granted to Tenant by Landlord and nothing stated herein is to be construed as restricting Landlord from granting rights to other parties or persons in, upon or under the Leased Premises. Without limiting the generality of the foregoing, the parties specifically refer to rights relating to sewers, water pipes and mains, drainage tiles and pipes, gas main and pipelines and other associated uses. In addition, Landlord shall have the right to enter upon the Leased Premises at any time and from time to time during the Term to (a) show the same to prospective tenants, mortgagees and/or purchasers, and to place "For Rent" and/or "For Sale" signs thereon and (b) to conduct any and all vegetation management in, on, or about the Leased Premises in accordance with Landlord's then current vegetation management practices and procedures.

**26. RIGHT OF ENTRY.**

A. Tenant agrees that Landlord and Landlord's agents, representatives, employees, contractors, licensees, invitees, tenants, successors and assigns (collectively, "**Landlord Parties**"), shall have the right to enter the Leased Premises at any time Landlord deems necessary, to alter, modify, augment, supplement, improve, upgrade, use, operate, repair, replace, install, construct, maintain or protect Landlord's Facilities and to conduct vegetation management activities, including

the right to cut down, trim and remove any trees, brush or other vegetation that interferes with or potentially interferes with Landlord's Facilities on the Leased Premises as Landlord deems necessary in its sole discretion. Tenant shall not plant any trees or other vegetation on the Leased Premises without the prior written consent of Landlord which it may withhold in its sole discretion. Landlord has the right to require Tenant to remove and relocate any paving, improvements or property owned or used by Tenant at the Leased Premises, in connection with the use, operation, maintenance, repair, installation and/or removal of Landlord's Facilities by any Landlord Party, and/or or in connection with any other use (present or future) of the Leased Premises by the Landlord Parties, all of which removal and relocation shall be at Tenant's sole cost and expense. In the event that Tenant fails to remove and/or relocate any such paving, improvements or property upon notice from Landlord, then Landlord shall have the right (but not the obligation) to remove such paving, improvements or property on Tenant's behalf, and at Tenant's cost, and Tenant shall promptly reimburse Landlord for any costs and expenses paid or incurred by Landlord in connection therewith. Tenant agrees that it will cooperate with Landlord in connection with any entry on, and work at, the Leased Premises by the Landlord Parties, and shall coordinate Tenant's use of the Leased Premises with any use of the Leased Premises by any of the Landlord Parties, including but not limited to vegetation management. Landlord shall not in any event be liable for inconvenience, disruption, disturbance, loss of business or other damage to Tenant by reason of any entry on, or work at, the Leased Premises by any Landlord Party, or on account of bringing materials, supplies, and equipment into or through the Leased Premises. Tenant understands that the business of the Landlord involves, among other things, the construction, installation, maintenance, operation, and use of Landlord's Facilities now or which may hereafter be erected or installed upon, along, on, over, across or under the Leased Premises, or property adjacent thereto, which are used or useful in connection with the generation, conversion, transmission or distribution of electricity and gas and communications services. Tenant covenants and agrees (as a specific condition of this Lease) that Tenant and each member of the Tenant Group will not, under any circumstances whatsoever, touch, handle, tamper with or contact, directly or indirectly, any of the Landlord's Facilities, nor damage, destroy, interfere with, obstruct or otherwise adversely affect, Landlord's Facilities.

B. Landlord and its representatives may enter the Leased Premises at all reasonable times for the purpose of inspecting the Leased Premises, or to show the Leased Premises to prospective purchasers, investors, encumbrancers, or tenants. In the case of an emergency, Landlord or its agents may enter the Leased Premises without prior notice, and may enter forcibly, without liability to Tenant, and without affecting this Lease. During the final twelve (12) months of the Term, Landlord may place customary "For Sale" or "For Lease" signs on the Leased Premises

**27. LANDLORD'S RIGHT TO TRANSFER.** This Lease shall not in any manner or to any extent limit or restrict the right of Landlord to use or dispose of the Leased Premises as Landlord may in its discretion desire, subject to rights of Tenant hereunder. Landlord shall have the right, without notice to or consent from Tenant, to assign this Lease to any person or entity that succeeds (directly, indirectly or by operation of law) to any of Landlord's right, title or interest in or to the Leased Premises.

**28. TENANT'S PROPERTY.** It is expressly understood and agreed that all equipment and other personal property that Tenant may install upon the Leased Premises during the Term shall remain the property of Tenant and shall be removed by Tenant (as set forth in Section 7 hereof), at its sole cost and expense, at the expiration of the term of this Lease or at any time prior thereto.

**29. HOLDING OVER.** Tenant shall have no right to remain in possession of all or any part of the Leased Premises after the expiration of the Term. In the event that Tenant remains in possession of all or any part of the Leased Premises after the expiration or earlier termination of the Term, at Landlord's option (exercised by giving Tenant written notice): (a) such tenancy shall be deemed to be either (at Landlord's

sole option) a periodic tenancy from month-to-month only, or a tenancy at sufferance terminable at will by Landlord; (b) such tenancy shall not, unless Landlord otherwise elects (as set forth above), constitute a renewal or extension of this Lease for any further Term; and (c) such tenancy may be terminated by Landlord upon the earlier of thirty (30) days' prior written notice or the earliest date permitted by law. In the event Tenant remains in possession after the expiration or earlier termination of the Term, then: (i) Landlord shall have the right to charge Tenant a monthly Base Rent equal to Landlord's estimate (as determined by Landlord in its sole discretion) of two hundred percent (200%) of the fair market monthly rental value of the Leased Premises, and any other sums due under this Lease shall be payable in the amount and at the times specified in this Lease, and (ii) Tenant agrees to the extent permitted by law to indemnify, defend (with counsel acceptable to Landlord, which acceptance shall not be unreasonably withheld) and hold the Indemnified Parties harmless from and against any and all Losses and Claims sustained, incurred and/or brought against any of the Indemnified Parties by reason of such retention of possession of the Leased Premises (which may include, without limitation, any Claims made by any actual or prospective subsequent lessee or other user or occupant of the Leased Premises or any portion thereof). Any such month-to-month tenancy or tenancy at sufferance shall be subject to every other term, condition, and covenant contained in this Lease.

### **30. SUBORDINATION; ESTOPPEL.**

A. This Lease and the rights of Tenant hereunder shall be and are hereby made expressly subject and subordinate at all times to the lien of any mortgage now or hereafter existing against all or any portion of the Leased Premises. Tenant acknowledges that its title is and always shall be subordinate to the title of the owner of the Leased Premises and nothing herein contained shall empower Tenant to do any act which can, shall or may encumber the title of the owner of the Leased Premises. In confirmation of such subordination, Tenant shall promptly execute and deliver any instrument that Landlord or any mortgagee of Landlord may request to evidence such subordination no later than ten (10) business days after Landlord's request therefor. If any mortgagee of Landlord (or its successors or assigns), or any other person or entity, shall succeed to the rights of Landlord under this Lease, whether through possession or foreclosure action or delivery of a new lease or deed, then at the request of such party so succeeding to Landlord's rights ("**Successor Landlord**") and upon Successor Landlord's written agreement to accept Tenant's attornment, Tenant shall attorn to and recognize Successor Landlord as Tenant's Landlord under this Lease, and shall promptly execute and deliver any instrument that Successor Landlord may reasonably request to evidence such attornment. Upon such attornment this Lease shall continue in full force and effect as, or as if it were, a direct lease between Successor Landlord and Tenant upon all of the terms, conditions and covenants as are set forth in this Lease and shall be applicable after such attornment.

B. Tenant agrees, at any time and from time to time, as requested by Landlord, upon not less than ten (10) days' prior notice, to execute and deliver to Landlord a written statement executed and acknowledged by Tenant, (a) stating that this Lease is then in full force and effect and has not been modified (or if modified, setting forth all modifications), (b) setting forth the Base Rent, (c) setting forth the date to which the Rent has been paid, (d) stating whether or not, to the best knowledge of the Tenant, Landlord is in default under this Lease, and if so, setting forth the specific nature of all such default, (e) stating whether there are any subleases affecting the Leased Premises, (f) stating the address of Tenant to which all notices and communication under the Lease shall be sent, and the Commencement Date, and (g) containing any other matters reasonably requested by Landlord. Tenant acknowledges that any statement delivered pursuant to this paragraph may be relied upon by others with whom Landlord may be dealing, including any purchaser or owner of the Leased Premises, or of Landlord's interest in the Leased Premises or any lender or mortgagee of Landlord. If Tenant fails to execute and return such written statement to Landlord

within such ten (10) day period, such failure shall constitute Tenant's agreement as to the accuracy of the information contained in the written statement submitted to Tenant by Landlord.

**31. MISCELLANEOUS.**

A. Illinois Commerce Commission Approval. Landlord and Tenant acknowledge that Landlord is a public utility regulated by the Illinois Commerce Commission ("**Commission**") and other governmental authorities, and this Lease and the obligations of the parties hereto are subject to all Legal Requirements applicable to Landlord as a public utility. Although it is not expected that the Commission's or other governmental authorities' approval will be required for this Lease, the rights and obligations of the parties hereunder are conditioned upon the Commission's and any other applicable governmental authorities' approval of this Lease, under any circumstances in which such approval is required. It is further agreed and understood that this Lease may be terminated by Landlord immediately at any time in the event that Landlord is required to do so by the Commission or some other governmental authority.

B. Notices. Whenever notice is required to be given pursuant to this Lease, the same shall be either personally delivered, sent by a nationally recognized overnight delivery service, postage prepaid, or sent via United States certified mail, return receipt requested, postage prepaid, and addressed to the parties at their respective addresses as follows:

If to Landlord:

Commonwealth Edison Company  
Three Lincoln Centre 4th Floor  
Oakbrook Terrace, IL 60181  
Attn: Real Estate Asset Management

with a copy to:

Exelon Business Services Company, LLC  
Law Department  
10 South Dearborn Street, 49<sup>th</sup> Floor  
Chicago, Illinois 60603  
Attn: Assistant General Counsel – Real Estate

If to Tenant:

Lake County Forest Preserve District  
1899 Winchester Road  
Libertyville, Illinois 60073  
Attn: Ken Jones

or at such other addresses as any party, by written notice in the manner specified above to the other party hereto, may designate from time to time. Unless otherwise specified to the contrary in this Lease, all notices shall be deemed to have been given upon receipt (or refusal of receipt) thereof.

C. Prohibition on Recording. To the maximum extent permitted under Legal Requirements, Tenant agrees not to record this Lease. This Section will survive the termination or expiration of this Lease.

D. Waiver of Jury Trial. Landlord and Tenant, by this Section, waive trial by jury in any action, proceeding, or counterclaim brought by either of the parties to this Lease against the other on any matters whatsoever arising out of or in any way connected with this Lease, the relationship of Landlord and Tenant, Tenant's use or occupancy of the Leased Premises, or any other claims, and any emergency statutory or any other statutory remedy.

E. Captions. The section headings appearing in this Lease are for convenience of reference only and are not intended, to any extent and for any purpose, to limit or define the text of any section or any subsection hereof.

F. Binding Effect. The covenants, conditions, and agreements contained in this Lease will bind and inure to the benefit of Landlord and Tenant and their respective heirs, distributees, executors, administrators, successors and permitted assigns. In the event that Tenant is comprised of more than one individual or entity, the obligations of such individuals or entities under this Lease shall be joint and several.

G. Entire Agreement. This Lease, the exhibits and addenda, if any, contain the entire agreement between Landlord and Tenant regarding the subject matter hereof, and fully supersede all prior written or oral agreements and understandings between the parties pertaining to such subject matter. No promises or representations, except as contained in this Lease, have been made to Tenant respecting the condition or the manner of operating the Leased Premises.

H. Further Assurances. Each party agrees that it will execute and deliver such other documents and take such other action as may be reasonably requested by the other party to effectuate the purposes and intention of this Lease.

I. No Waiver. The failure of either party to enforce at any time any provision of this Lease shall not be construed to be a waiver of such provision, nor in any way to affect the validity of this Lease or any part hereof or the right of such party thereafter to enforce each and every such provision. No waiver of any breach of this Lease shall be held to constitute a waiver of any other or subsequent breach.

J. No Third Party Beneficiaries. Landlord and Tenant agree and acknowledge that, except as expressly set forth herein, there are no intended third party beneficiaries of this Lease nor any of the rights and privileges conferred herein.

K. Governing Law. The terms and provisions of this Lease shall be governed by and construed in accordance with the laws of the State of Illinois. With respect to any suit, action or proceeding relating to this Lease (each a "**Proceeding**"), the parties hereto each irrevocably: (a) agree that any such Proceeding shall be commenced, brought, tried, litigated and consummated in the courts of the State of Illinois located in the County of Cook or (as applicable) in the United States District Court for the Northern District of Illinois, (b) submit to the exclusive jurisdiction of the courts of the State of Illinois located in the County of Cook and the United States District Court for the Northern District of Illinois, and (c) waive any objection which they may have at any time to the laying of venue of any Proceeding brought in any court, waive any claim that any Proceeding brought in any such court has been brought in an inconvenient forum, and further waive the right to object, with respect to such Proceeding, that any such court does not have jurisdiction over such party.

L. Counterparts. This Lease may be executed by the parties in counterparts. Each such counterpart shall be deemed an original and all such counterparts, taken together, shall constitute one and the same agreement.

M. Subordinate. This Lease, and all of Tenant's rights and interests hereunder, are subject and subordinate to any and all recorded and unrecorded easements, licenses, leases and permits, and all other matters (whether recorded or unrecorded) affecting the Leased Premises (or title thereto) dated prior to the date of this Lease.

N. Severability. If any term, provision or condition in this Lease shall, to any extent, be invalid or unenforceable, the remainder of this Lease (or the application of such term, provision or condition to persons or circumstances other than in respect of which it is invalid or unenforceable) shall not be affected thereby, and each term, provision and condition of this Lease shall be valid and enforceable to the fullest extent permitted by law.

O. Time of the Essence. Time is of the essence of this Lease, and each and every term and provision hereof.

P. No Partnership. None of the terms or provisions of this Lease shall be deemed to create a partnership between or among the parties hereto in their respective businesses or otherwise, nor shall any of the terms or provisions of this Lease cause them to be considered joint venturers or members of any joint enterprise.

Q. Not an Employee. By signing this Lease, Tenant affirms and states that it is not an employee of Commonwealth Edison Company nor Exelon Corporation, nor any of their respective parents, subsidiaries or affiliates, nor does Tenant have any affiliated interest in any such entities.

R. No Oral Change. This Lease cannot be changed orally or by course of conduct, and no executory agreement, oral agreement or course of conduct shall be effective to waive, change, modify or discharge it in whole or in part unless the same is in writing and is signed by the party against whom enforcement of any waiver, change, modification or discharge is sought.

S. Tenant's Authority. Tenant represents and warrants that it has full right, power and authority to execute and deliver this Lease, and to perform each and all of its duties and obligations hereunder. If Landlord so requests, Tenant shall provide Landlord with reasonable written evidence of such right, power and authority.

T. Termination of Lease Based Upon Change In Law. If any Legal Requirement is enacted or modified during the Term, and such enactment or modification places any additional material burden on Landlord (as determined by Landlord) as a result of Tenant's use or occupancy of the Leased Premises for any purpose, or if the use of the Leased Premises by Tenant would violate any Legal Requirements hereinafter enacted or modified, then (without limiting any other rights or remedies of Landlord hereunder) Landlord shall have the right to terminate this lease effective as of the effective date of such Legal Requirement is so enacted or modified.

U. Negotiated. The parties acknowledge that the parties and their counsel have reviewed and revised this Lease and that the normal rule of construction to the effect that any ambiguities are to be resolved against the drafting party shall not be employed in the interpretation of this Lease or any exhibits or amendments hereto.

V. Brokers. Tenant represents and warrants to Landlord that Tenant has dealt with no broker, finder or similar person or entity in connection with this Lease, or Tenant's use or occupancy of the Leased Premises. Tenant agrees to indemnify, defend (with counsel acceptable to Landlord) and hold Landlord harmless from and against any and all Claims and Losses brought against, sustained or incurred by Landlord by reason of Tenant's breach of the foregoing representation and warranty.

W. Tenant's Authority to Act. This Lease shall be executed for and on behalf of the Tenant pursuant to a resolution adopted by the County Board of Tenant, at a regular meeting held \_\_\_\_\_, 20\_\_, and signed by the officers therein designated as signatories and attested by the clerk of Tenant.

X. Confidentiality. Tenant acknowledges and agrees that the terms and conditions of this Lease, including, without limitation, the Rent, and all other books, records, documents, files and other information, whether computerized, written or oral, pertaining to Landlord, Landlord's affiliates or the Leased Premises which was or shall be provided to Tenant from the negotiations of this Lease throughout the term of the Lease (collectively, "**Confidential Information**") is nonpublic, confidential or proprietary relating to Landlord, its business operations and the Leases Premises, and that Landlord would be irreparably damaged if Tenant's confidential knowledge of such information were disclosed to or utilized on behalf of any other person, firm, corporation or any other tenant of Landlord. Tenant agrees that any Confidential Information provided to Tenant is, and shall remain, property owned by Landlord, and Tenant shall have no right in or to such information other than to use the Confidential Information for the purposes set forth in the Lease. Tenant agrees to keep confidential and agrees to cause its respective employees, associates, agents, attorneys and advisors to keep confidential any and all of Confidential Information. **[OPTIONAL: Landlord acknowledges that Tenant is a municipal corporation, and information is permitted to be disclosed at a public meeting but only to the extent law requires such disclosure.]**

Y. Additional Requirements. Tenant shall comply the Additional Requirements listed on Exhibit E attached hereto and made a part hereof.

[REMAINDER OF THE PAGE INTENTIONALLY LEFT BLANK]



IN WITNESS WHEREOF, Landlord and Tenant have executed this Lease on the date first written above.

**LANDLORD:**

COMMONWEALTH EDISON COMPANY

By: \_\_\_\_\_  
Name: Wanda Anderson  
Its: Senior Manager of Real Estate and Facilities

**TENANT:**

\_\_\_\_\_

By \_\_\_\_\_  
Name: \_\_\_\_\_  
Title: \_\_\_\_\_

ATTEST:

By: \_\_\_\_\_

**EXHIBITS**

- A Leased Premises
- B [Reserved]
- C-1 & C-2 Fencing and Barrier Requirements
- D Insurance Requirements
- E Additional Requirements

**EXHIBIT A**

**Leased Premises**

**CONTRACT NUMBER: 20100037**

**R/W Name: WAUKEGAN – CRYSTAL LAKE R/W**

**PARCELS: T41-36, T42-37, T42-38, T42-39, T42-48, T42-49, T42-50, T42-51, T42-51A, T42-52, T42-53 IN AVON TOWNSHIP**

**SW ¼ SECTION 19, TOWNSHIP 45, RANGE 10E**

**OF THE THIRD PRINCIPAL MERIDIAN**

**LAKE COUNTY – AVON TWP, ILLINOIS**

**COMED REGION NORTH**

**PIN: 06-30-300-014, 06-30-100-005, 6-30-100-001, 06-15-300-029, 06-15-400-001, 06-15-400-002, 06-14-300-001, 06-14-400-001, 07-27-200-001**

# Exhibit A-1

Lake County Forest Preserve District  
 1899 W Winchester Rd  
 Libertyville, IL 60048  
 847-968-3351  
 www.lcfpd.org

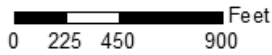

## Legend

- Forest Preserve Property
- ComEd ROW
- Leased Premises
- Additional Area to be Maintained

Courtesy Copy Only.  
 Property boundaries indicated are provided for general location purposes. Wetland and flood limits shown are approximate and should not be used to determine setbacks for structure or as a basis for purchasing property.

2023 Aerial Photo

Prepared using information from Nearmap & Lake County Department of Information and Technology: GIS/Mapping Division  
 18 North County Street  
 Waukegan, Illinois 60085-4357  
 and Nearmap US, Inc

Map Prepared 26 February 2024



# Exhibit A-2

## Legend

- Forest Preserve Property
- ComEd ROW
- Leased Premises
- Additional Area to be Maintained

Lake County Forest Preserve District  
1899 W Winchester Rd  
Libertyville, IL 60048  
847-968-3351  
www.lcfd.org

Courtesy Copy Only.  
Property boundaries indicated are provided for general location purposes. Wetland and flood limits shown are approximate and should not be used to determine setbacks for structure or as a basis for purchasing property.

Prepared using information from Nearmap & Lake County Department of Information and Technology: GIS/Mapping Division  
18 North County Street  
Waukegan, Illinois 60085-4357  
and Nearmap U.S, Inc

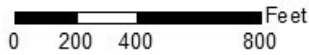

2023 Aerial Photo

Map Prepared 26 February 2024



# Exhibit A-3

## Legend

- Forest Preserve Property
- ComEd ROW
- Leased Premises
- Additional Area to be Maintained

Lake County Forest Preserve District  
1899 W Winchester Rd  
Libertyville, IL 60048  
847-968-3351  
www.lcfd.org

Courtesy Copy Only.  
Property boundaries indicated are provided  
for general location purposes. Wetland  
and flood limits shown are approximate and  
should not be used to determine setbacks for  
structure or as a basis for purchasing property.

Prepared using information from Nearmap  
& Lake County Department of Information  
and Technology: GIS/Mapping Division  
18 North County Street  
Waukegan, Illinois 60085-4357  
and Nearmap US, Inc

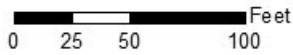

2023 Aerial Photo

Map Prepared 26 February 2024



# Exhibit A-4

Lake County Forest Preserve District  
1899 W Winchester Rd  
Libertyville, IL 60048  
847-968-3351  
www.lcfd.org

## Legend

- Forest Preserve Property
- ComEd ROW
- Leased Premises
- Additional Area to be Maintained

Courtesy Copy Only.  
Property boundaries indicated are provided for general location purposes. Wetland and flood limits shown are approximate and should not be used to determine setbacks for structure or as a basis for purchasing property.

Prepared using information from Nearmap & Lake County Department of Information and Technology: GIS/Mapping Division  
18 North County Street  
Waukegan, Illinois 60085-4357  
and Nearmap US, Inc

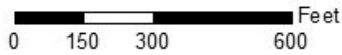

2023 Aerial Photo

Map Prepared 26 February 2024

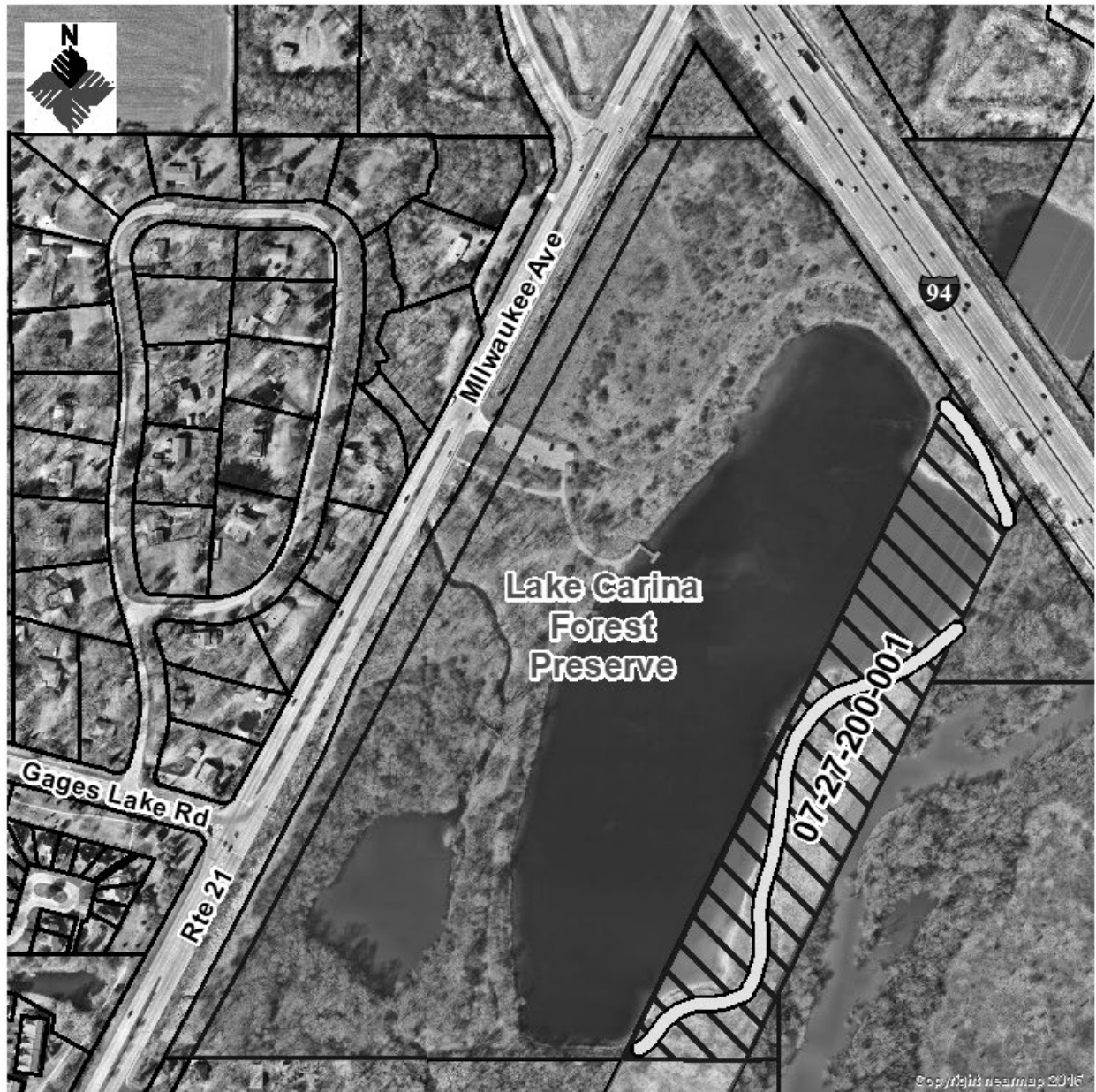

**EXHIBIT B**

**[Base Rent Schedule][Reserved]**

**[Intentionally blank]**

## EXHIBIT C-1 and C-2 Fencing and Barrier Requirements

6-16-94  
**C9522**  
PAGE 1 OF 1

REVISES SPEC. DATED 3-9-81

6-16-94  
**C9522**  
PAGE 1 OF 1

### LOCKING ARRANGEMENTS FOR TRANSMISSION RIGHT-OF-WAY GATES & TRANSMISSION LINE TERMINALS

TYPICAL RIGHT OF WAY GATE

**C9522.1**  
SINGLE LOCK ARRANGEMENT

**C9522.2**  
ARRANGEMENT FOR TWO OR MORE LOCKS

PETITIONER'S LOCK

ITEM	DESCRIPTION	EM	S.I.	UNIT	QUANTITY	
					.1	.2
A	LOCK, PADLOCK, SHACKLE OPENING 1 1/2" IN. X 3/8 IN. PLATED STEEL	-	716027	EA.	1	1
B	STRAIGHT LINK CHAIN, HOT DIPPED GALVANIZED	-	786756	FT.	3	3

**ENGINEERING INFORMATION**

1. CHAIN ORDERING DESCRIPTION STRAIGHT LINK CHAIN, TRADE SIZE 5/0. MATERIAL DIAMETER 0.26 IN., LINK WIDTH 0.44 IN. X LINK LENGTH 1.52 IN.

TRANSMISSION RELIABILITY AND STANDARDS

COMMONWEALTH EDISON COMPANY  
SYSTEM STANDARD

X T L S C O E  
REVISION

ACAD



## PROTECTIVE BARRIERS FOR TRANSMISSION STRUCTURES (69KV AND ABOVE)

PROTECTIVE BARRIERS FOR TRANSMISSION STRUCTURES  
ADJACENT TO PARKING AREAS (USING CONCRETE-FILLED STEEL PIPES)  
C9520.1\_

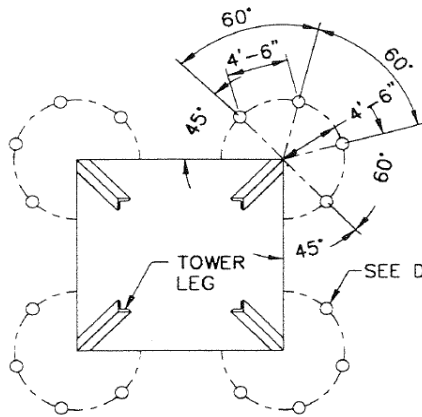

**PLAN**  
TYPICAL TOWER LEG PROTECTION  
C9520.11

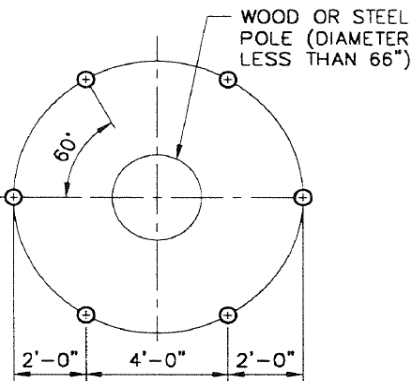

**PLAN**  
TYPICAL WOOD OR STEEL POLE PROTECTION  
C9520.12

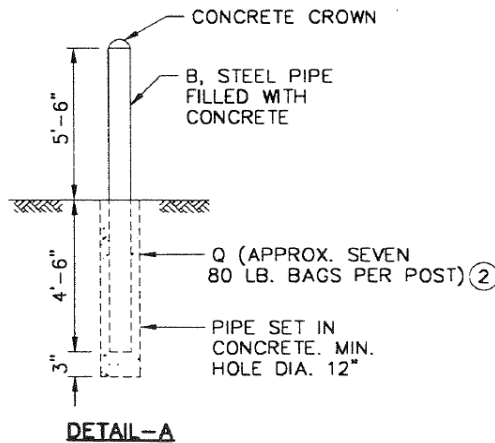

**PROTECTIVE BARRIERS FOR TRANSMISSION STRUCTURES  
 NEAR ROADWAYS (USING HIGHWAY GUARDRAIL)  
 C9520.2\_**

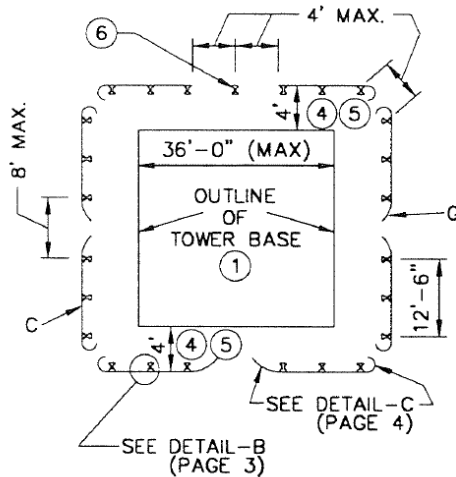

**PLAN**  
 TYPICAL TOWER PROTECTION  
 ON ALL SIDES  
 C9520.21

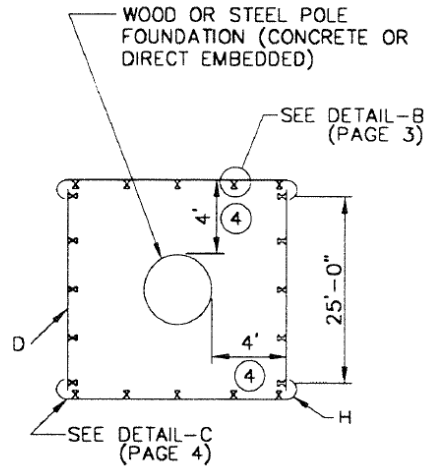

**PLAN**  
 TYPICAL POLE PROTECTION  
 ON ALL SIDES  
 C9520.22

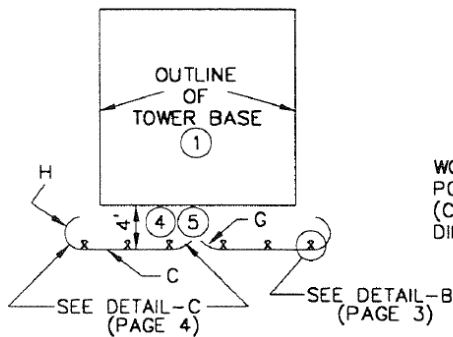

**PLAN**  
 TYPICAL TOWER PROTECTION  
 ON ONE SIDE  
 C9520.23

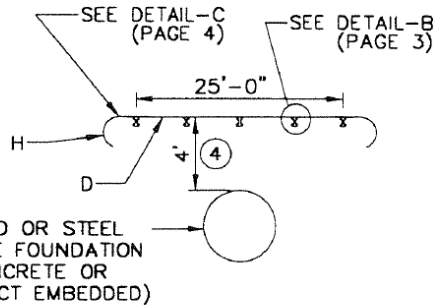

**PLAN**  
 TYPICAL POLE PROTECTION  
 ON ONE SIDE  
 C9520.24

GUARDRAIL SUPPORT DETAILS, C9520.2\_

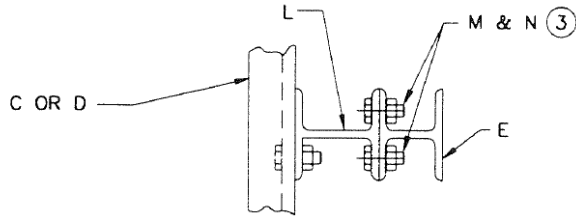

**DETAIL-B. PLAN**

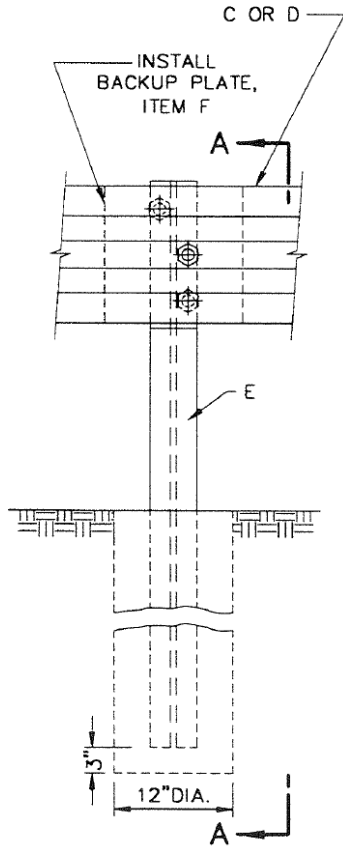

**DETAIL-B. ELEVATION**

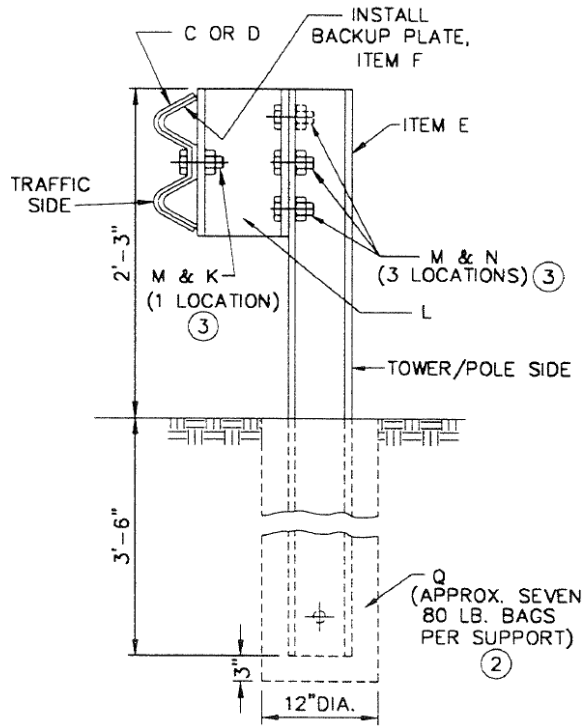

**SECTION A-A**

**GUARDRAIL END SUPPORT/TERMINAL SECTION DETAILS, C9520.2\_**

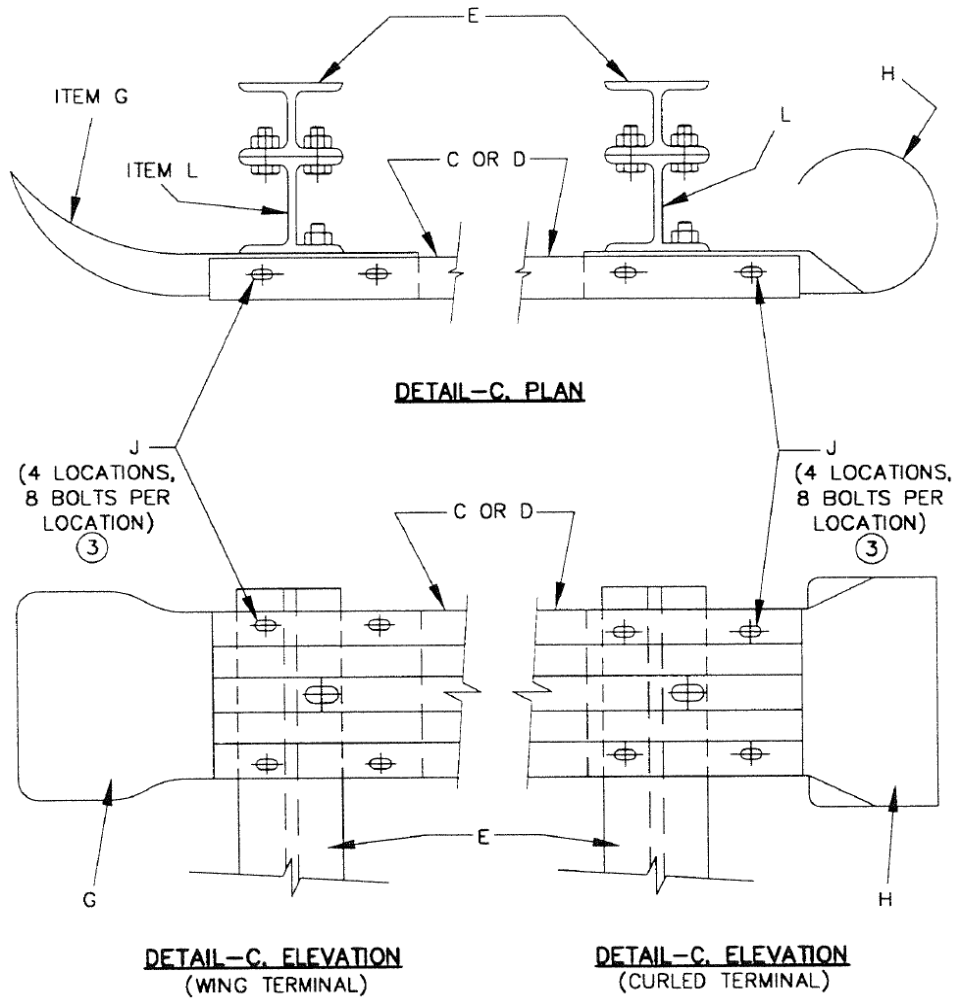

**PROTECTIVE BARRIERS FOR TRANSMISSION STRUCTURES  
 ADJACENT TO PARKING AREAS (USING PARKING CURBS)**  
 C9520.3\_

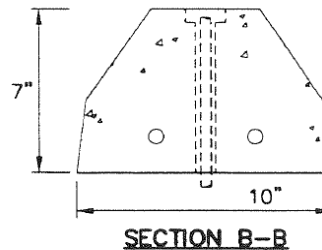
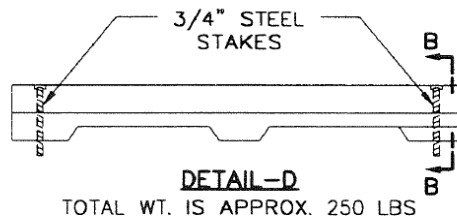
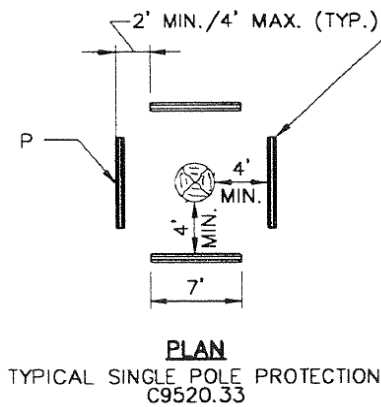
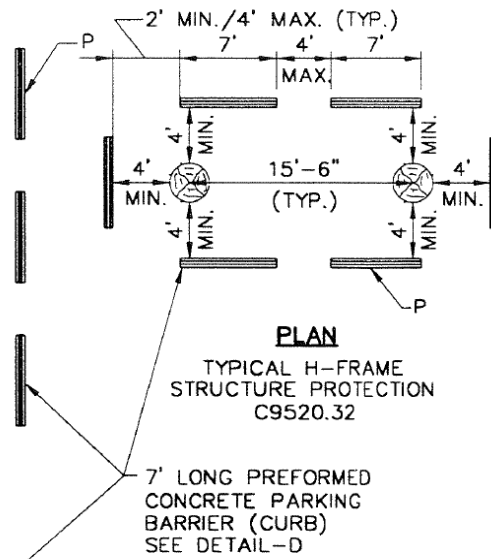
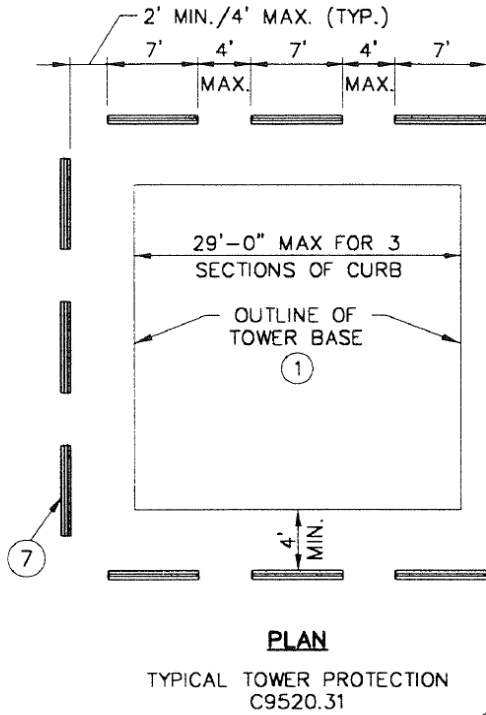

**APPLICATION**

- THIS STANDARD SHALL BE USED FOR INSTALLATION OF VEHICLE BARRIERS AROUND TRANSMISSION STRUCTURES AND ILLUSTRATES THE DIFFERENT TYPES OF VEHICLE BARRIERS WHICH MAY BE USED FOR TRANSMISSION STRUCTURE PROTECTION.

**INFORMATION**

- ① ACTUAL STRUCTURE TYPE, SHAPE & BASE DIMENSIONS MAY VARY. DETAILS WILL BE FURNISHED ON THE PROJECT DRAWINGS WHERE DIFFERENT THAN SHOWN.
- ② ITEM "Q", (S.I.#701129) CAN BE REPLACED WITH 4000 PSI READY-MIX CONCRETE PER EM48003. ONE CONCRETE TRUCK WITH 7 CUBIC YARD CAPACITY IS APPROXIMATELY EQUIVALENT TO 220 BAGS OF S.I.#701129 AFTER ADDING WATER AND MIXING.
- ③ NUTS ON GUARDRAIL BARRIER SHALL BE TIGHTENED WITH A TORQUE WRENCH TO A TORQUE VALUE OF 75 FOOT-POUNDS.
- ④ SPACING OF BARRIERS FROM STRUCTURE OUTLINE AS SHOWN IS MINIMUM AND MAY BE INCREASED WHERE NECESSARY.
- ⑤ THE TOWER PROTECTIVE BARRIER SPACING SHALL BE BASED ON ACTUAL TOWER BASE DIMENSIONS. DETAILS SHOWN ARE APPLICABLE TO A TOWER WITH A MAXIMUM BASE DIMENSION OF 36'-0". ADD ONE UNIT AT EACH SIDE IF THE TOWER BASE DIMENSION EXCEEDS 36'-0".
- ⑥ WHERE THIS DIMENSION CAN BE KEPT AT 4 FEET OR LESS, WITH CORNER OPENING NO MORE THAN 4 FEET. THE INTERMEDIATE POST SHOWN HERE CAN BE ELIMINATED.
- ⑦ NUMBER OF UNITS DEPENDENT ON SIZE OF TOWER BUT SPACES BETWEEN UNITS SHALL NOT EXCEED THE 4 FEET SHOWN, NOR SHALL THE MINIMUM DISTANCE FROM TOWER BE CHANGED. ADD ONE UNIT AT EACH SIDE IF THE TOWER BASE DIMENSION EXCEEDS 25'-0".
- ⑧ THE LOCATIONS OF THE PROTECTIVE BARRIERS WILL BE STAKED BY THE OWNER UNLESS OTHERWISE INDICATED ON THE PROJECT DRAWINGS.
- ⑨ CARE SHALL BE TAKEN TO AVOID DISTURBANCE OF ALL AREAS OUTSIDE OF THE IMMEDIATE WORK AREA. ANY DAMAGE TO PROPERTY SHALL BE IMMEDIATELY REPAIRED. ALL ADJACENT PROPERTY SHALL BE RESTORED TO ITS ORIGINAL CONDITION IMMEDIATELY AFTER THE INSTALLATION OF THE VEHICLE BARRIERS.

ITEM	DESCRIPTION	EM	SI	UNIT	QUANTITY																			
					.11	.12	.21	.22	.23	.24	.31	.32	.33											
A																								
B	CONDUIT, RIGID, STEEL, 5 IN. IPS, GALV., 10FT. LONG.			EA		16	6																	
C	GUARD RAIL, BEAM TYPE, 13'-6 1/2" LONG, 10 GAGE STEEL, HOT DIP GALVANIZED (AASHTO M-180).	10220 ITEM 1		EA				8		2														
D	GUARD RAIL, BEAM TYPE, 26'-1/2" LONG, 10 GAGE STEEL, HOT DIP GALVANIZED (AASHTO M-180).	10220 ITEM 2		EA					4		1													
E	I BEAM POST SUPPORT, 4" X 6" X 5'-9" LONG, 9 LBS./FT., A36, CARBON STEEL, HOT DIPPED GALVANIZED W6 X 9.	10220 ITEM 3		EA				25	20	6	5													
F	BACKUP PLATE 12 1/4" X 12 1/2" LONG, 10 GAGE STEEL, HOT DIP GALVANIZED.	10220 ITEM 4		EA				8	12	2	3													
G	WING, TERMINAL SECTION, 10 GAGE STEEL, HOT DIP GALVANIZED (AASHTO M-180)	10220 ITEM 5		EA				8		2														
H	CURLED, TERMINAL SECTION, 10 GAGE STEEL, HOT DIP GALVANIZED (AASHTO M-180)	10220 ITEM 6		EA				8	4	2	2													
J	BOLT, CARRIAGE 5/8" DIA. x 1 1/4" LONG, A307 BOLT WITH NUT WASHER, HOT DIPPED GALVANIZED	10220 ITEM 7		EA				128	32	32	16													
K	WASHER 3" X 1 3/4" X 3/16" THICK (8 GAGE WASHER) A36 STEEL HOT DIPPED GALV.	10220 ITEM 8		EA				24	20	6	5													
L	I BEAM BOLTS W 8 X 10 X 1'-1" LONG, A36 CARBON STEEL, HOT DIPPED GALV., 10# PER FT.	10220 ITEM 9		EA				24	20	6	5													
M	MACHINE BOLTS 5/8" DIA. X 2" LONG A307 BOLT HOT DIPPED GALVANIZED WITH NUT A563	10257		EA				96	80	24	20													
N	5/8" DIA. FLAT WASHER (HOT DIPPED GALVANIZED)	10220 ITEM 11		EA				168	140	42	35													
P	CURB, PARKING, 7 FT. LONG X 7 IN. HIGH X 10 IN. WIDE, W/TWO 3/4" X 18" STEEL STAKES			EA								12	6	4										
Q	MIXTURE, CONCRETE 80 LB. (2)			BC				42	175	140	42	35												

## **EXHIBIT D**

### **Insurance Requirements**

(current 2/13/2018)

A. Tenant agrees to require its contractors, before commencing any work on the Leased Premises to purchase and maintain, or at the option of Tenant to itself purchase and maintain, at the cost of Tenant or its contractors, a policy or policies of insurance issued by insurance companies authorized to do business in the State of Illinois, having ratings of A-/VII or better in the Best's Key Rating Insurance Guide (latest edition in effect at the latest date stated in the Certificates of Insurance) and in a form satisfactory to Landlord as follows:

#### COVERAGE #1

Workers' Compensation Insurance with statutory limits, as required by the state in which the work is to be performed, –and Employers' Liability Insurance with limits not less than One Million dollars (\$1,000,000.00) each accident/occurrence

#### COVERAGE #2

Commercial General Liability (CGL) Policy or Policies (with coverage consistent with ISO CG 0001 (12 04)) covering all contractors, subcontractors and all their subcontractors with limits not less than Four Million dollars (\$4,000,000.00) per occurrence covering liability for bodily injury and property damage arising from premises, operations, independent contractors, personal injury/advertising injury, blanket contractual liability and products/completed operations for not less than three (3) years from the date the work is accepted. (CGL insurance includes, but is not limited to coverage for claims against Landlord for injuries to employees of Tenant and its contractors or any subcontractors) Landlord shall be added as an Additional Insured providing coverage consistent with ISO Form CG 20 26 11 85 or the combination of ISO Form CG 20 10 10 01 and CG 20 37 10 01.

#### COVERAGE #3

Automobile Liability in an amount of not less than one million dollars (\$1,000,000) per accident for bodily injury and property damage, covering all owned, leased, rented or non-owned vehicles, which shall include automobile contractual liability coverage.

Policies covering contractors may substitute lower limits for any of the policies listed above, provided that Contractors maintains an umbrella or excess liability policy or policies which provide a total minimum limit of four million dollars (\$4,000,000) per occurrence for general liability and one million dollars (\$1,000,000) for automobile liability, and that all other requirements of this insurance clause are satisfied by such umbrella or excess policy or policies.



If any work on the Leased Premises involves or includes Contractor handling, transporting, disposing, or performing work or operations with hazardous substances, contaminants, waste, toxic materials, or any potential pollutants, Tenant and/or contractors shall purchase and maintain pollution legal liability applicable to bodily injury; property damage, including loss of use of damaged property or of property that has not been physically injured or destroyed; cleanup costs; and defense, including costs and expenses incurred in the investigation, defense, or settlement of claims; all in connection with any loss arising from the Leased Premises. Coverage shall be maintained in an amount of at least five million dollars (\$5,000,000) per loss and aggregate. Coverage shall apply to sudden and non-sudden pollution conditions resulting from the escape or release of smoke, vapors, fumes, acids, alkalis, toxic chemicals, liquids, or gases, waste materials, or other irritants, contaminants, or pollutants. Landlord shall be included as an additional insured and the policy shall be primary with respect to Landlord as the additional insured.

There shall be furnished to Landlord, prior to commencing the work above described a certificate of insurance showing the issuance of insurance policies pursuant to the requirements contained in Coverages #1, #2, and #3 of this paragraph. Insurance coverage as required herein shall be kept in force until all work has been completed. All policies shall contain a provision that coverages afforded under the policies will not be canceled or material change until at least thirty (30) days prior written notice (ten (10) days in the case of nonpayment of premium) has been given to Landlord.

Insurance coverage provided by Tenant and its contractors shall not include any of the following; any claims-made insurance policies; any self-insured retention or deductible amount greater than two hundred fifty thousand dollars (\$250,000) unless approved in writing by Landlord; any endorsement limiting coverage available to Landlord which is otherwise required by this Article; and any policy or endorsement language that (i) negates coverage to Landlord for Landlord's own negligence, (ii) limits the duty to defend Landlord under the policy, (iii) provides coverage to Landlord only if Tenant or its contractors are negligent, (iv) permits recovery of defense costs from any additional insured, or (v) limits the scope of coverage for liability assumed under a contract.

To the extent permitted by applicable Laws, all above-mentioned insurance policies shall provide the following:

- (1) Be primary and non-contributory to any other insurance carried by Landlord
- (2) Contain cross-liability coverage as provided under standard ISO Forms' separation of insureds clause; and
- (3) Provide for a waiver of all rights of subrogation which Tenant's, or its Contractors' insurance carrier might exercise against Landlord; and
- (4) Any Excess or Umbrella liability coverage will not require contribution before it will apply

Landlord hereby reserves the right to amend, correct and change from time-to-time the limits, coverages and forms of policies as may be required from Tenant and/or its contractors.

#### WAIVER OF SUBROGATION

Tenant and its contractors shall waive all rights of subrogation against Landlord under those policies procured in accordance with this Lease.

## **EXHIBIT E**

### **Additional Requirements**

Tenant shall adhere to the following requirements:

1. Tenant shall maintain the Leased Premises and Additional Area to be Maintained (which includes the open grass way area) of the Landlord right of way property.
2. The metallic goal structures are not to be permanent fixtures and must be removed after each use. It is suggested the metallic structures be grounded to guard against induced voltages.
3. No part of the field or goal structures shall be located within ten (10) feet of any Landlord equipment or facilities.
4. Care must be used when mowing the fields such that no Landlord structures are touched.
5. If lighting and landscaping is required, plans and details must be provided to ComEd for review to ensure safety clearances are not violated.
6. Tenant's facilities on Landlord's property should be designed for HS20 axle loading per AASHTO highway specifications in order to withstand Landlord's construction traffic.
7. Tenant must not excavate and /or store material or construction equipment within 10 feet of the existing metallic and/or wood structures installed on Landlord property. Tenant shall contact the Overhead Transmission Engineering department with any questions concerning this request.
8. Tenant must use care when working on Landlord property to avoid damage to existing facilities and equipment. The owners of the various pipelines and /or owners of underground facilities shall be contacted by the Tenant to provide any restrictions such as grade cover and/ or specific protection and/or restrictions during any penetration and/or disturbing of the Landlord property and surface.
9. There are existing buried hand holes for the LLR fiber in the area. If these hand holes were paved over during the installation of the bike path it poses a maintenance concern. Slack coils exist in the hand holes for emergency restoration purposes. The cable route should be located to verify the newly installed bike path is not over the cable or hand holes. If it is over the hand holes access to those hand holes needs to be addressed by either rerouting the path or other means. This applies to plan se 05-655 and 06-689.
10. Staging and stockpiling of material during construction must not exceed ten (10) feet in elevation above grade. Construction equipment shall not be placed on the upper-most sections of the stockpiles.
11. Tenant must remove all scrub brush, limbs and/or tree trunks from the Leased Premises. Burning of vegetation, scrub brush, limbs and/or tree trunks is not permitted.
12. Tenant must not plant trees within fifteen (15) feet of existing overhead transmission facilities, distribution structures or other Landlord's Facilities.
13. Tenant shall only plant vegetation and /or trees that will not exceed ten (10) feet in elevation at maturity.
14. Landlord reserves the right to trim vegetation and /or trees and remove any vegetation or trees to (i) assure National Electrical Safety Code (NESC) electrical clearances are met (ii) perform maintenance and/or repairs to Landlord's Facilities.
15. The path shall not meander, but it may curve around existing structures and shall maintain fifteen (15) foot spacing from all existing transmission structures.
16. At all path access points, Tenant must post highly visible signs indicating that motorized vehicular use of the path is prohibited. Further, Tenant shall take responsibility to ensure that motorized vehicular use does not occur.
17. The path surface for Tenant's project cannot use aggregate concrete or curbs. A crushed limestone or asphalt surface is acceptable.
18. Tenant's proposed grade change cannot exceed eight (8) inches within the Landlord's property and must ensure that the existing drainage and storm water will not pool on the Leased Premises or adjacent properties.

19. Any damage to Landlord's property caused by Tenant shall be repaired at Tenant's expense.
20. Tenant shall not place obstructions on the Leased Premises that may restrict Landlord's ability to access, operate and maintain existing and future transmission and distribution facilities. Tenant shall not leave trenches open overnight.
21. Due to the presence of Landlord's electrical wires located on the Leased Premises, no vehicles, equipment or anything else having a height more than fourteen (14) feet from grade level including, but not limited to any equipment attached to vehicles or equipment such as antennas, shall be placed, driven, moved or transported thereon. Tenant shall not permit any activity which could result in a wire to ground electrical contact or damage to Landlord's Facilities. Such activities include, but are not limited to flying kites, model airplanes, driving minibikes, go carts and snowmobiles.
22. Tenant shall not leave construction equipment and materials on Leased Premises when there is no work activity actually in progress, including overnight.
23. When working in the vicinity of Landlord's electric distribution/transmission lines during installation, operation, maintenance or otherwise, Tenant shall comply with OSHA requirements of a minimum twenty (20) feet working clearance distance to be maintained between the booms, arms or other parts that can be raised on the equipment of Tenant or Tenant's contractor and Landlord's existing 138,000 and 345,000 volt electric transmission conductors. Under no circumstances shall truck beds be raised underneath Landlord's distribution and /or transmissions lines. This paragraph shall be added to any construction drawings.
24. Tenant acknowledges that the Landlord does use heavy equipment and that Landlord will not be responsible for any damage to the Tenant's facilities that may occur due to the Landlord's right to access Landlord's property to operate and maintain new and existing transmission and distribution facilities.
25. Upon completion of Tenant's project, Tenant must remove any equipment, construction debris and material from Landlord's property and restore any other disturbed areas of the Landlord's property to their pre-construction condition.
26. All applicable environmental permits must be obtained by Tenant at Tenant's sole cost, including, if required, Wetlands and National Pollutant Discharge Elimination System (NPDES) stormwater permits as required under the Clean Water Act as well as any other applicable environmental permits.
27. Tenant shall comply with requirements of all permits, which may include site monitoring, reporting and restoration extending well beyond the construction time period.
28. Tenant shall comply with all applicable regulations including implementation of a Stormwater Pollution Prevention Plan (SWPPP) and a Soil Erosion and Sediment Control Plan (SESC) to minimize sediment pollution in stormwater runoff as well as any other required practices.
29. If the project requires excavation of soil on the Leased Premises, such work shall be performed at Tenant's cost with a contractor selected by Landlord.
30. If the project requires additional soil, only clean fill shall be used.
31. No hazardous materials may be stored on Landlord's property including in any vehicle.
32. Pervious materials shall be used in the construction of any paths on the Leased Premises.
33. A high level summary of the project plans shall be provided by Tenant to Landlord for Landlord's review and approval prior to any construction, including the following:
  - A letter that summarizes the results of Tenant's analysis of what types of environmental permits, plans, and controls are required (e.g., wetlands, SWPPP, SESC, threatened and endangered species impacts, etc.)
  - A copy of any required environmental permits
  - A copy of any environmental reports required by the permits
34. Tenant shall, at its expense, pay for all costs associated with any of the above items (consulting, permitting, cleanup, audit, etc.).

### **Additional Lease Requirements**

1. Detailed on-site wetland delineation must be conducted by qualified personnel to determine any changes to the wetland boundaries and the quality of the wetland habitat.
2. Lessee must maintain all required environmental permits including Wetlands Permitting as required under the Clean Water Act Section 404.
3. Any changes to the soil or excavation of the soil must be removed by a ComEd COC (Contractor of Choice)
4. Lessee must continue to follow all applicable environmental laws and regulations.
5. Lessee is responsible for all costs associated with any of the above items, ie; consulting, permitting, etc.
6. The continued use of the subject property is permitted only for maintenance and use of a multi-use path, as submitted. No improvements or construction activities are approved with this response.
7. Motorized vehicles are not permitted on the leased property.
8. No construction debris, soil, fill material, or spoils may be stored on ComEd property.
9. No hazardous materials, including petroleum products, may be stored, used, or transferred on ComEd property. No fueling of lawn mowers or similar maintenance equipment is allowed on ComEd property.
10. Tenant will be held responsible for the clean-up of any spills (oil, antifreeze, fuel, etc.) as this could be a potential source of contamination and future liability for ComEd.
11. In the event of a leak/spill on ComEd property, Tenant must notify ComEd within 24 hours and provide a written report within 5 business days.
12. Tenant is responsible for the maintenance of any onsite stormwater management system at the subject property and will be held responsible for any adverse drainage issues that arise for the duration of the lease. Inlet filters must be placed on all storm sewer manholes on ComEd property and must be properly maintained.
13. Tenant is not permitted to develop the unpaved areas or change the grading of the property without prior authorization from ESD. This includes activities of adding gravel or other fill-in activities to the surface of ComEd property. Any repairs or maintenance within an existing gravel area may be filled only with virgin uniform gravel (CA-6 or equivalent) and compacted so that the patch does not exceed the height of the surrounding gravel surface. The use of asphalt grindings or other foreign fill material is not permitted.
14. At lease-end, the site must be returned to its original natural condition, including seeding, as necessary. However, ComEd has the discretion to allow the property to remain in its improved condition.
15. Tenant must follow all applicable environmental laws and regulations and obtain all required environmental permits.
16. 11. Tenant must follow all federal, state, and local wetlands requirements, including United States Army Corps of Engineers and Lake County regulations and guidelines.
17. Good housekeeping must be maintained at all times on the leased ComEd property.
18. Tenant must assume responsibility for all maintenance of the leased ComEd property. This includes keeping the entire property free of garbage, debris, and any third-party dumping. If third-party dumping occurs on or around the leased premises, Tenant must notify ComEd immediately or be held responsible for cleanup of any illegally dumped materials.